

# 04. Orbit Stability and the Phase Amplitude Formulation\*

Prof. Steven M. Lund

Physics and Astronomy Department  
Facility for Rare Isotope Beams (FRIB)  
Michigan State University (MSU)

MSU PHY 905 and US Particle Accelerator School  
“Accelerator Physics”

Steven M. Lund and Yue Hao

East Lansing, Michigan

January, 2020

\* Research supported by:

(Version 20200130)

FRIB/MSU: U.S. Department of Energy Office of Science Cooperative Agreement DE-SC0000661 and National Science Foundation Grant No. PHY-1102511

# S5: Linear Transverse Particle Equations of Motion without Space-Charge, Acceleration, and Momentum Spread

## S5A: Hill's Equation

Neglect:

- ◆ Space-charge effects
- ◆ Nonlinear applied focusing and bends
- ◆ Acceleration
- ◆ Momentum spread effects:

Then the transverse particle equations of motion reduce to [Hill's Equation](#):

$$x''(s) + \kappa(s)x(s) = 0$$

$x = \perp$  particle coordinate

(i.e.,  $x$  or  $y$  or possibly combinations of coordinates)

$s$  = Axial coordinate of reference particle

$' = \frac{d}{ds}$  Derivative with respect to axial coordinate

$\kappa(s)$  = Lattice focusing function (linear fields)

For a **periodic lattice**:

$$\kappa(s + L_p) = \kappa(s)$$
$$L_p = \text{Lattice Period}$$

/// Example: Hard-Edge Periodic Focusing Function

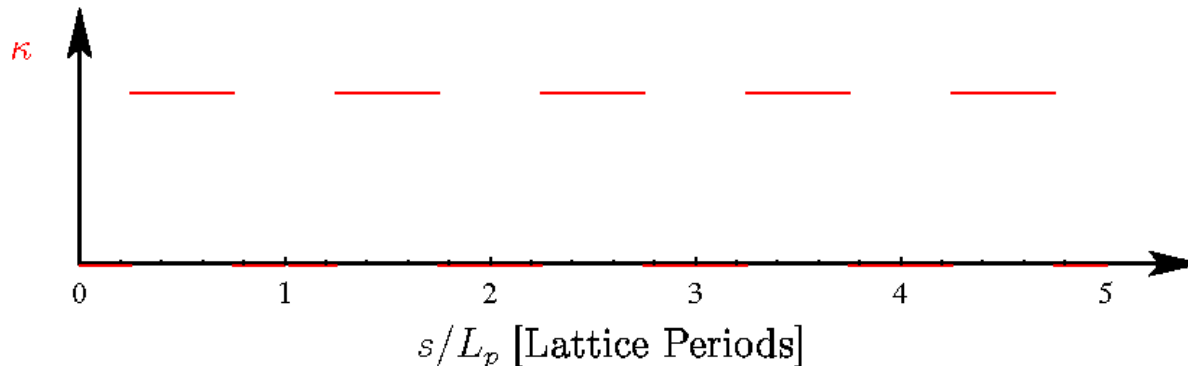

For a **ring** (i.e., circular accelerator), one also has the “superperiod” condition: ///

$$\kappa(s + \mathcal{C}) = \kappa(s)$$
$$\mathcal{C} = \mathcal{N}L_p = \text{Ring Circumfrance}$$
$$\mathcal{N} = \text{Superperiod Number}$$

- ◆ Distinction matters when there are (field) construction errors in the ring
  - Repeat with superperiod but not lattice period
  - Will cover in lectures on: **Particle Resonances**

/// Example: Period and Superperiod distinctions for errors in a ring

- \* Magnet with systematic defect will be felt every lattice period
- X Magnet with random (fabrication) defect felt once per lap

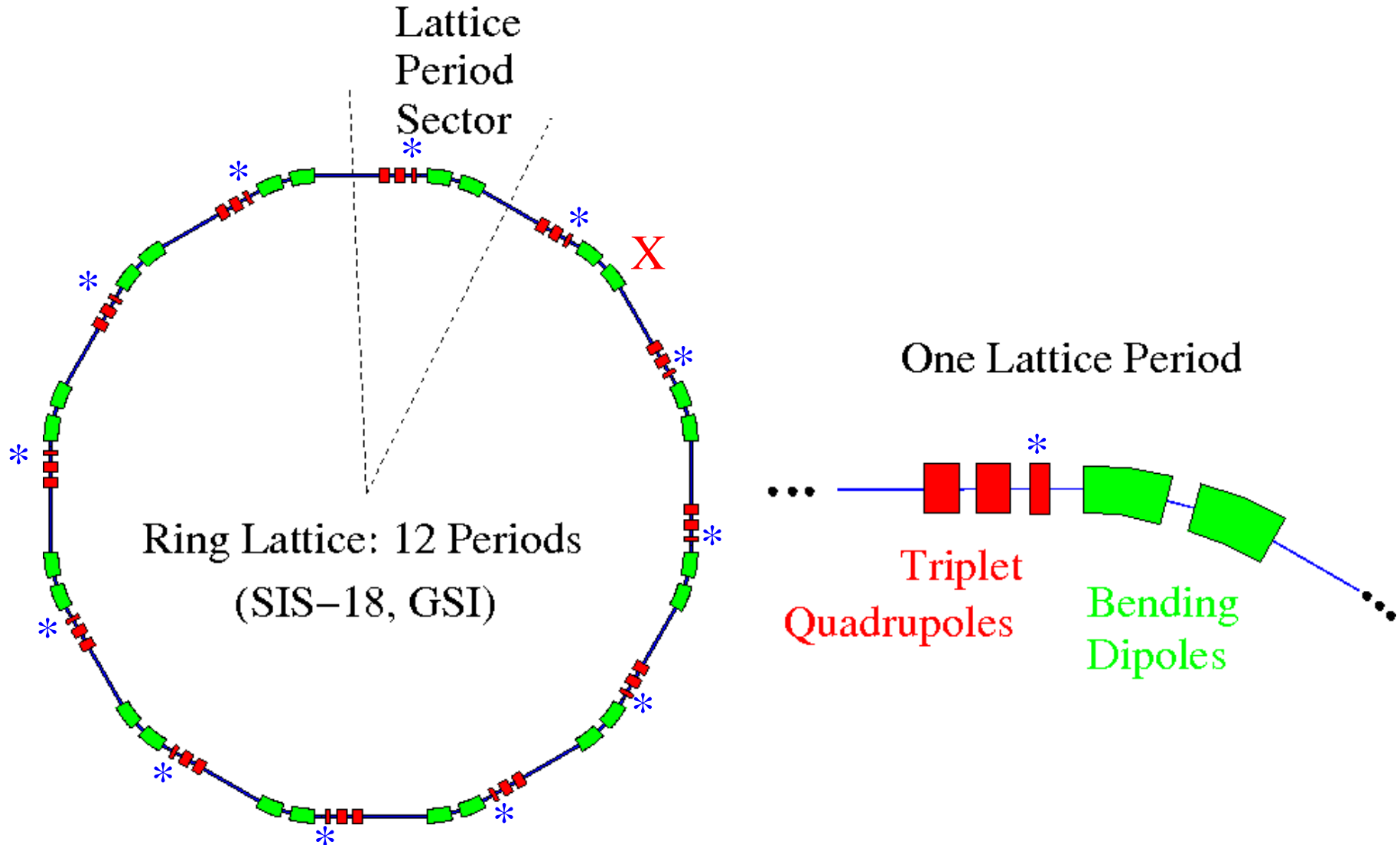

## S5B: Transfer Matrix Form of the Solution to Hill's Equation

Hill's equation is linear. The solution with **initial condition**:

$$\begin{aligned}x(s = s_i) &= x(s_i) \\x'(s = s_i) &= x'(s_i)\end{aligned}$$

$s = s_i$  = Axial location  
of initial condition

can be uniquely expressed in matrix form (**M** is the **transfer matrix**) as:

$$\begin{aligned}\begin{bmatrix} x(s) \\ x'(s) \end{bmatrix} &= \mathbf{M}(s|s_i) \cdot \begin{bmatrix} x(s_i) \\ x'(s_i) \end{bmatrix} \\ &= \begin{bmatrix} C(s|s_i) & S(s|s_i) \\ C'(s|s_i) & S'(s|s_i) \end{bmatrix} \cdot \begin{bmatrix} x(s_i) \\ x'(s_i) \end{bmatrix}\end{aligned}$$

Where  $C(s|s_i)$  and  $S(s|s_i)$  are “cosine-like” and “sine-like” **principal trajectories** satisfying:

$$C''(s|s_i) + \kappa(s)C(s|s_i) = 0 \quad C(s_i|s_i) = 1 \quad C'(s_i|s_i) = 0$$

$$S''(s|s_i) + \kappa(s)S(s|s_i) = 0 \quad S(s_i|s_i) = 0 \quad S'(s_i|s_i) = 1$$

This follows trivially because:

$$x(s) = x(s_i)C(s|s_i) + x'(s_i)S(s|s_i)$$

satisfies the differential equation:

$$x''(s) + \kappa(s)x(s) = 0$$

with initial condition:

$$x(s = s_i) = x(s_i)$$

$$x'(s = s_i) = x'(s_i)$$

Because:

$$\begin{aligned} x''(s) + \kappa(s)x(s) &= x(s_i) [C''(s|s_i) + \kappa(s)C(s|s_i)] \\ &\quad + x'(s_i) [S''(s|s_i) + \kappa(s)S(s|s_i)] = 0 \end{aligned}$$

since the terms in [...] vanish and the initial condition is satisfied:

$$x(s_i) = x(s_i) \overset{1}{C}(s_i|s_i) + x'(s_i) \overset{0}{S}(s_i|s_i) = x(s_i)$$

$$x'(s_i) = x(s_i) \overset{0}{C}'(s_i|s_i) + x'(s_i) \overset{1}{S}'(s_i|s_i) = x'(s_i)$$

**Transfer** matrices were covered in Hao lectures for a few simple focusing systems discussed with the additional assumption of piecewise constant  $\kappa(s)$

1) **Free Drift:**  $\kappa = 0$   $x'' = 0$

$$\mathbf{M}(s|s_i) = \begin{bmatrix} 1 & s - s_i \\ 0 & 1 \end{bmatrix}$$

2) **Continuous Focusing:**  $\kappa = k_{\beta 0}^2 = \text{const} > 0$   $x'' + k_{\beta 0}^2 x = 0$

$$\mathbf{M}(s|s_i) = \begin{bmatrix} \cos[k_{\beta 0}(s - s_i)] & \frac{1}{k_{\beta 0}} \sin[k_{\beta 0}(s - s_i)] \\ -k_{\beta 0} \sin[k_{\beta 0}(s - s_i)] & \cos[k_{\beta 0}(s - s_i)] \end{bmatrix}$$

3) **Solenoidal Focusing:**  $\kappa = \hat{\kappa} = \text{const} > 0$   $x'' + \hat{\kappa} x = 0$

Results are expressed within the rotating **Larmor Frame**

(same as continuous focusing with reinterpretation of variables)

$$\mathbf{M}(s|s_i) = \begin{bmatrix} \cos[\sqrt{\hat{\kappa}}(s - s_i)] & \frac{1}{\sqrt{\hat{\kappa}}} \sin[\sqrt{\hat{\kappa}}(s - s_i)] \\ -\sqrt{\hat{\kappa}} \sin[\sqrt{\hat{\kappa}}(s - s_i)] & \cos[\sqrt{\hat{\kappa}}(s - s_i)] \end{bmatrix}$$

4) **Quadrupole Focusing-Plane:**  $\kappa = \hat{\kappa} = \text{const} > 0$       $x'' + \hat{\kappa}x = 0$

(Obtain from continuous focusing case)

$$\mathbf{M}(s|s_i) = \begin{bmatrix} \cos[\sqrt{\hat{\kappa}}(s - s_i)] & \frac{1}{\sqrt{\hat{\kappa}}} \sin[\sqrt{\hat{\kappa}}(s - s_i)] \\ -\sqrt{\hat{\kappa}} \sin[\sqrt{\hat{\kappa}}(s - s_i)] & \cos[\sqrt{\hat{\kappa}}(s - s_i)] \end{bmatrix}$$

5) **Quadrupole DeFocusing-Plane:**  $\kappa = -\hat{\kappa} = \text{const} < 0$       $x'' - \hat{\kappa}x = 0$

(Obtain from quadrupole focusing case with  $\sqrt{\hat{\kappa}} \rightarrow i\sqrt{\hat{\kappa}}$       $i = \sqrt{-1}$  )

$$\mathbf{M}(s|s_i) = \begin{bmatrix} \cosh[\sqrt{\hat{\kappa}}(s - s_i)] & \frac{1}{\sqrt{\hat{\kappa}}} \sinh[\sqrt{\hat{\kappa}}(s - s_i)] \\ \sqrt{\hat{\kappa}} \sinh[\sqrt{\hat{\kappa}}(s - s_i)] & \cosh[\sqrt{\hat{\kappa}}(s - s_i)] \end{bmatrix}$$

6) **Thin Lens:**  $\kappa(s) = \frac{1}{f}\delta(s - s_0)$       $x'' + \frac{1}{f}\delta(s - s_0)x = 0$

$s_0 = \text{const} = \text{Axial Location Lens}$

$f = \text{const} = \text{Focal Length}$

$\delta(x) = \text{Dirac-Delta Function}$

$$\mathbf{M}(s_0^+ | s_0^-) = \begin{bmatrix} 1 & 0 \\ -\frac{1}{f} & 1 \end{bmatrix}$$



## S5C: Wronskian Symmetry of Hill's Equation

An important property of this linear motion is a **Wronskian invariant/symmetry**:

$$\begin{aligned} W(s|s_i) &\equiv \det \mathbf{M}(s|s_i) = \det \begin{bmatrix} C(s|s_i) & S(s|s_i) \\ C'(s|s_i) & S'(s|s_i) \end{bmatrix} \\ &= C(s|s_i)S'(s|s_i) - C'(s|s_i)S(s|s_i) = 1 \end{aligned}$$

/// Proof: Abbreviate Notation  $C \equiv C(s|s_i)$  etc.

Multiply Equations of Motion for  $C$  and  $S$  by  $-S$  and  $C$ , respectively:

$$-S(C'' + \kappa C) = 0$$

$$+C(S'' + \kappa S) = 0$$

Add Equations:

$$CS'' - SC'' + \kappa(CS - SC) = 0$$

$$\implies \frac{dW}{ds} = \frac{d}{ds}(CS' - C'S) = CS'' - SC'' = 0$$

$$\implies W = \text{const}$$

Apply initial conditions:

$$W(s) = W(s_i) = C_i S'_i - C'_i S_i = 1 \cdot 1 - 0 \cdot 0 = 1$$

///

### /// Example: Continuous Focusing: Transfer Matrix and Wronskian

$$\kappa(s) = k_{\beta 0}^2 = \text{const} > 0$$

Principal orbit equations are simple harmonic oscillators with solution:

$$\begin{aligned} C(s|s_i) &= \cos[k_{\beta 0}(s - s_i)] & C'(s|s_i) &= -k_{\beta 0} \sin[k_{\beta 0}(s - s_i)] \\ S(s|s_i) &= \frac{\sin[k_{\beta 0}(s - s_i)]}{k_{\beta 0}} & S'(s|s_i) &= \cos[k_{\beta 0}(s - s_i)] \end{aligned}$$

Transfer matrix gives the familiar solution:

$$\begin{bmatrix} x(s) \\ x'(s) \end{bmatrix} = \begin{bmatrix} \cos[k_{\beta 0}(s - s_i)] & \frac{\sin[k_{\beta 0}(s - s_i)]}{k_{\beta 0}} \\ -k_{\beta 0} \sin[k_{\beta 0}(s - s_i)] & \cos[k_{\beta 0}(s - s_i)] \end{bmatrix} \cdot \begin{bmatrix} x(s_i) \\ x'(s_i) \end{bmatrix}$$

Wronskian invariant is elementary:

$$W = \cos^2[k_{\beta 0}(s - s_i)] + \sin^2[k_{\beta 0}(s - s_i)] = 1$$

///

Can exploit Wronskian condition to check all matrices

- Most simple (3d phase-space) expression of dynamics being Hamiltonian/Symplectic

## S5D: Stability of Solutions to Hill's Equation in a Periodic Lattice

The transfer matrix must be the same in any period of the lattice:

$$\mathbf{M}(s + L_p | s_i + L_p) = \mathbf{M}(s | s_i)$$

For a propagation distance  $s - s_i$  satisfying

$$NL_p \leq s - s_i \leq (N + 1)L_p \quad N = 0, 1, 2, \dots$$

the transfer matrix can be resolved as

$$\begin{aligned} \mathbf{M}(s | s_i) &= \mathbf{M}(s - NL_p | s_i) \cdot \mathbf{M}(s_i + NL_p | s_i) \\ &= \mathbf{M}(s - NL_p | s_i) \cdot [\mathbf{M}(s_i + L_p | s_i)]^N \\ &\quad \text{Residual} \qquad \qquad N \text{ Full Periods} \end{aligned}$$

For a lattice to have **stable orbits**, both  $x(s)$  and  $x'(s)$  should **remain bounded** on propagation through an arbitrary number  $N$  of lattice periods. This is equivalent to requiring that the **elements of  $\mathbf{M}$  remain bounded** on propagation through any number of lattice periods:

$$\mathbf{M}^N \equiv [\mathbf{M}^N_{ij}]$$

$$\lim_{N \rightarrow \infty} \left| \mathbf{M}^N_{ij} \right| < \infty \quad \implies \text{Stable Motion}$$

## Clarification of stability notion: Unstable Orbit

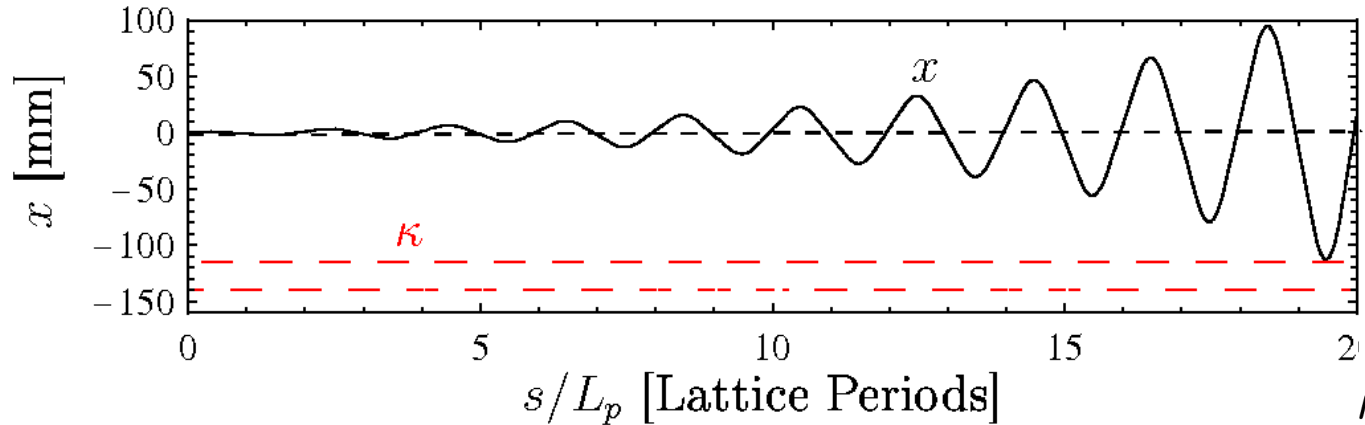

$$L_p = 0.5 \text{ m}$$

$$\eta = 0.5$$

$$\kappa = \begin{cases} 48/\text{m}^2 & \text{where } \kappa \neq 0 \\ 0 & \text{otherwise} \end{cases}$$

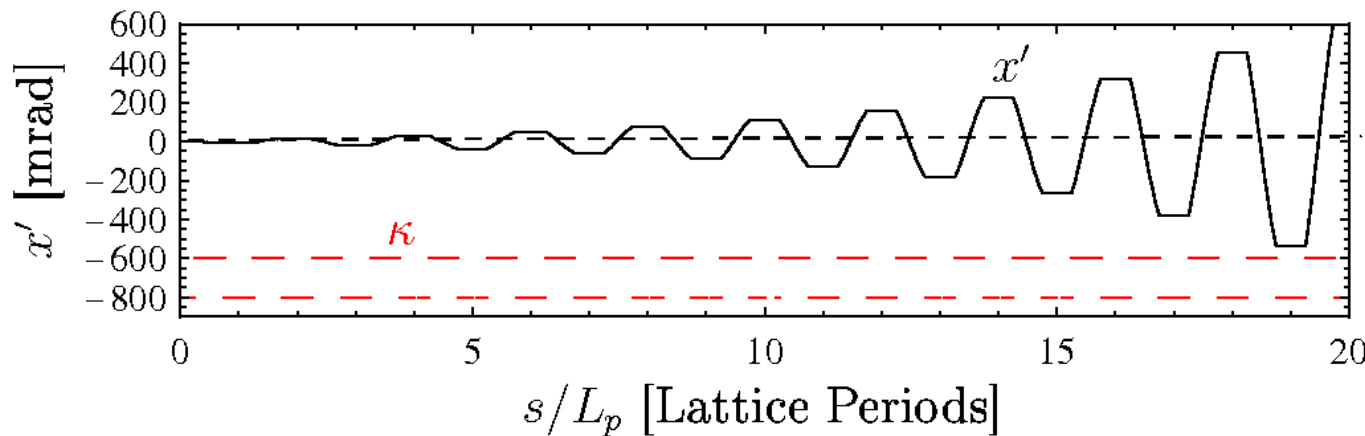

$$x(0) = 1 \text{ mm}$$

$$x'(0) = 0$$

For energetic particle:  $H = \frac{1}{2}x'^2 + \frac{1}{2}\kappa x^2 \sim \text{Large, but } \neq \text{const}$

where  $|x'|$  small,  $|x|$  large

where  $|x|$  small,  $|x'|$  large

The matrix criterion corresponds to our intuitive notion of stability: as the particle advances there are no large oscillation excursions in position and angle.

To analyze the **stability condition**, examine the **eigenvectors/eigenvalues** of **M** for transport through one lattice period:

$$\mathbf{M}(s_i + L_p | s_i) \cdot \mathbf{E} \equiv \lambda \mathbf{E}$$

$\mathbf{E}$  = Eigenvector

$\lambda$  = Eigenvalue

- ◆ Eigenvectors and Eigenvalues are generally complex
- ◆ Eigenvectors and Eigenvalues generally vary with  $s_i$
- ◆ Two independent Eigenvalues and Eigenvectors
  - Degeneracies special case

Derive the two independent eigenvectors/eigenvalues through analysis of the **characteristic equation**: Abbreviate Notation

$$\mathbf{M}(s_i + L_p | s_i) = \begin{bmatrix} C(s_i + L_p | s_i) & S(s_i + L_p | s_i) \\ C'(s_i + L_p | s_i) & S'(s_i + L_p | s_i) \end{bmatrix} \equiv \begin{bmatrix} C & S \\ C' & S' \end{bmatrix}$$

Nontrivial solutions to  $\mathbf{M} \cdot \mathbf{E} \equiv \lambda \mathbf{E}$  exist when (non-invertable coeff matrix):

$$\det \begin{bmatrix} C - \lambda & S \\ C' & S' - \lambda \end{bmatrix} = \lambda^2 - (C + S')\lambda + (CS' - SC') = 0$$

But we can apply the **Wronskian** condition:

$$CS' - SC' = 1$$

and we make the notational definition

$$C + S' = \text{Tr } \mathbf{M} \equiv 2 \cos \sigma_0$$

Reminder:

$$\mathbf{M} = \begin{bmatrix} C & S \\ C' & S' \end{bmatrix}$$

The **characteristic equation** then reduces to:

$$\lambda^2 - 2\lambda \cos \sigma_0 + 1 = 0 \qquad \cos \sigma_0 \equiv \frac{1}{2} \text{Tr } \mathbf{M}(s_i + L_p | s_i)$$

The use of  $2 \cos \sigma_0$  to denote  $\text{Tr } \mathbf{M}$  is in anticipation of later results (see **S6**) where  $\sigma_0$  is identified as the phase-advance of a stable orbit

There are two solutions to the characteristic equation that we denote  $\lambda_{\pm}$

$$\lambda_{\pm} = \cos \sigma_0 \pm \sqrt{\cos^2 \sigma_0 - 1} = \cos \sigma_0 \pm i \sin \sigma_0 = e^{\pm i \sigma_0}$$

$$\mathbf{E}_{\pm} = \text{Corresponding Eigenvectors} \qquad i \equiv \sqrt{-1}$$

Note that:

$$\lambda_+ \lambda_- = 1$$
$$\lambda_+ = 1/\lambda_-$$

Reciprocal Symmetry

Consider a vector of **initial conditions**:

$$\begin{bmatrix} x(s_i) \\ x'(s_i) \end{bmatrix} = \begin{bmatrix} x_i \\ x'_i \end{bmatrix}$$

The eigenvectors  $\mathbf{E}_{\pm}$  span two-dimensional space. So any initial condition vector can be expanded as:

$$\begin{bmatrix} x_i \\ x'_i \end{bmatrix} = \alpha_+ \mathbf{E}_+ + \alpha_- \mathbf{E}_-$$

$\alpha_{\pm} = \text{Complex Constants}$

Then using  $\mathbf{M} \cdot \mathbf{E}_{\pm} = \lambda_{\pm} \mathbf{E}_{\pm}$

$$\mathbf{M}^N(s_i + L_p | s_i) \cdot \begin{bmatrix} x_i \\ x'_i \end{bmatrix} = \alpha_+ \lambda_+^N \mathbf{E}_+ + \alpha_- \lambda_-^N \mathbf{E}_-$$

Therefore, **if**  $\lim_{N \rightarrow \infty} \lambda_{\pm}^N$  is bounded, then the motion is **stable**. This will always be the case if  $|\lambda_{\pm}| = |e^{\pm i\sigma_0}| \leq 1$ , corresponding to  $\sigma_0$  real with  $|\cos \sigma_0| \leq 1$

This implies **for stability** or the orbit that we must have:

$$\begin{aligned}\frac{1}{2} |\text{Trace } \mathbf{M}(s_i + L_p | s_i)| &= \frac{1}{2} |C(s_i + L_p | s_i) + S'(s_i + L_p | s_i)| \\ &= |\cos \sigma_0| \leq 1\end{aligned}$$

In a periodic focusing lattice, this important **stability condition** places restrictions on the lattice structure (focusing strength) that are generally interpreted in terms of **phase advance limits** (see: **S6**).

- ◆ Accelerator lattices almost always tuned for single particle stability to maintain beam control
  - Even for intense beams, beam centroid approximately obeys single particle equations of motion when image charges are negligible
- ◆ Space-charge and nonlinear applied fields can further limit particle stability
  - Resonances: see: **Particle Resonances ....**
  - Envelope Instability: see: **Transverse Centroid and Envelope ....**
  - Higher Order Instability: see: **Transverse Kinetic Stability**
- ◆ We will show (see: **S6**) that for stable orbits  $\sigma_0$  can be interpreted as the phase-advance of single particle oscillations



### /// Example: Continuous Focusing Stability

$$\kappa(s) = k_{\beta 0}^2 = \text{const} > 0$$

Principal orbit equations are simple harmonic oscillators with solution:

$$\begin{aligned} C(s|s_i) &= \cos[k_{\beta 0}(s - s_i)] & C'(s|s_i) &= -k_{\beta 0} \sin[k_{\beta 0}(s - s_i)] \\ S(s|s_i) &= \frac{\sin[k_{\beta 0}(s - s_i)]}{k_{\beta 0}} & S'(s|s_i) &= \cos[k_{\beta 0}(s - s_i)] \end{aligned}$$

Stability bound then gives:

$$\begin{aligned} \frac{1}{2} |\text{Trace } \mathbf{M}(s_i + L_p|s_i)| &= \frac{1}{2} |C(s_i + L_p|s_i) + S'(s_i + L_p|s_i)| \\ &= |\cos[k_{\beta 0}(s - s_i)]| \leq 1 \end{aligned}$$

- ◆ Always satisfied for real  $k_{\beta 0}$
- ◆ Confirms known result using formalism: continuous focusing stable
  - Energy not pumped into or out of particle orbit

///

The simplest example of the stability criterion applied to periodic lattices will be given in the problem sets: **Stability of a periodic thin lens lattice**

- ◆ Analytically find that lattice unstable when focusing kicks sufficiently strong

## More advanced treatments

♦ See: Dragt, *Lectures on Nonlinear Orbit Dynamics*, AIP Conf Proc 87 (1982) show that **symplectic 2x2 transfer matrices** associated with **Hill's Equation** have only **two possible classes of eigenvalue symmetries**:

### 1) Stable

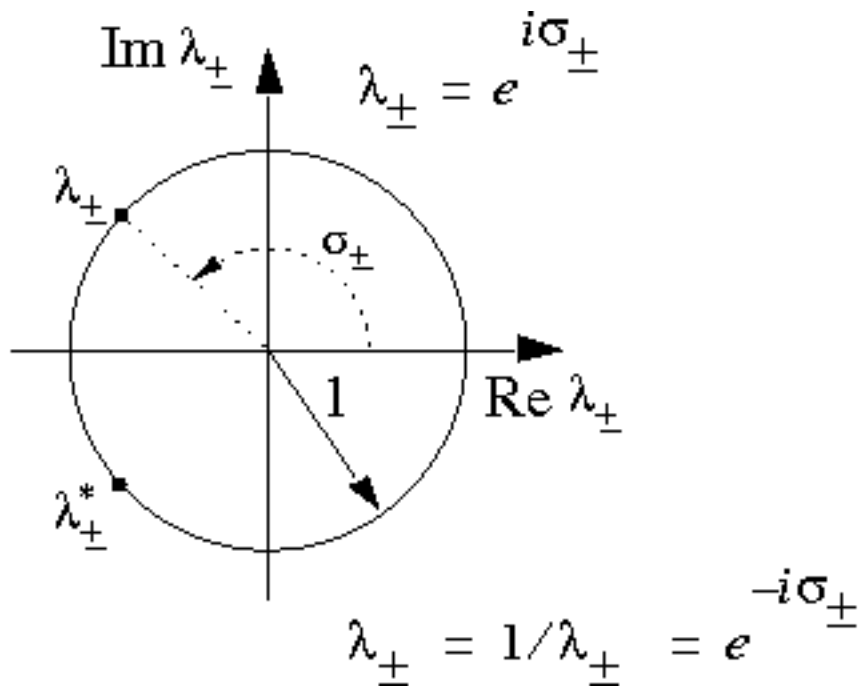

Occurs for:

$$0 \leq \sigma_0 \leq 180^\circ / \text{period}$$

♦ Limited class of possibilities simplifies analysis of focusing lattices

### 2) Unstable, Lattice Resonance

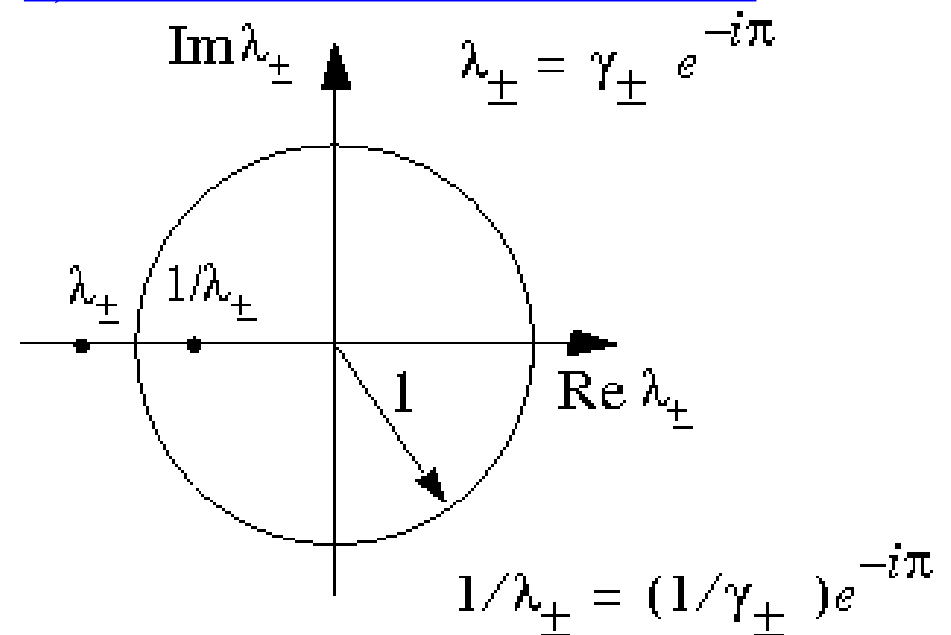

Occurs in bands when focusing strength is increased beyond  $\sigma_0 = 180^\circ / \text{period}$

# Eigenvalue structure as focusing strength is increased

## Weak Focusing:

- ◆ Make  $\kappa$  as small as needed (low phase advance  $\sigma_0$  )
- ◆ Always first eigenvalue case:  $|\lambda_{\pm}| = 1$ ,  $\lambda_+ = 1/\lambda_- = \lambda_-^*$

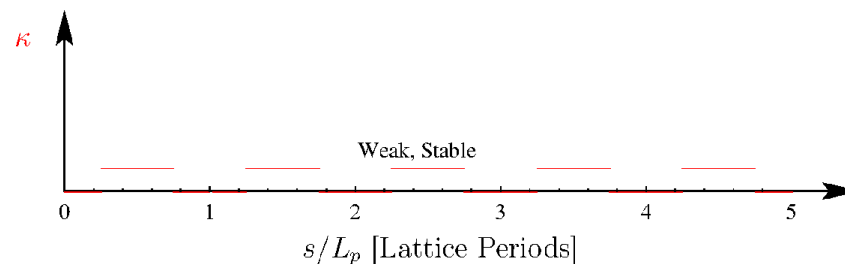
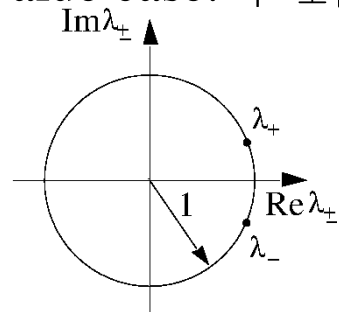

## Stability Threshold:

- ◆ Increase  $\kappa$  to stability limit (phase advance  $\sigma_0 = 180^\circ/\text{Period}$  )
- ◆ Transition between first and second eigenvalue case:  $\lambda_{\pm} = -1$

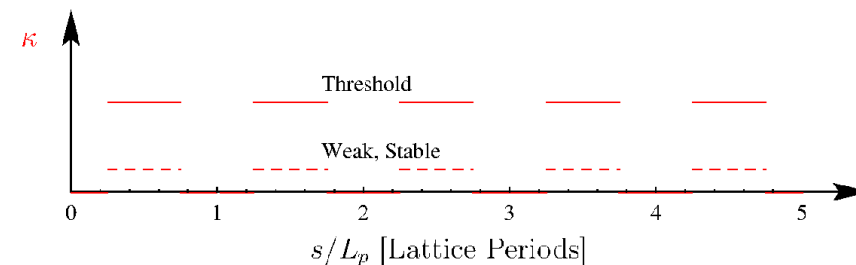
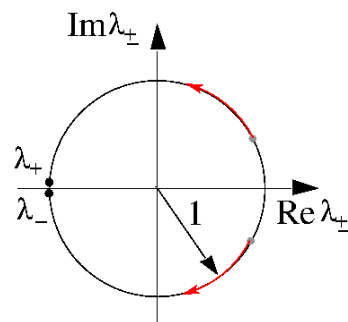

## Instability:

- ◆ Increase  $\kappa$  beyond threshold (phase advance  $\sigma_0 = 180^\circ/\text{Period}$  )
- ◆ Second eigenvalue case:  $|\lambda_+| \neq 1$ ,  $\lambda_+ = 1/\lambda_-$   $\lambda_{\pm}$  both real and negative

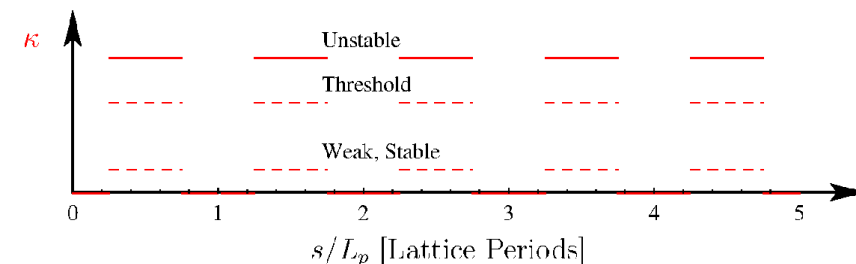
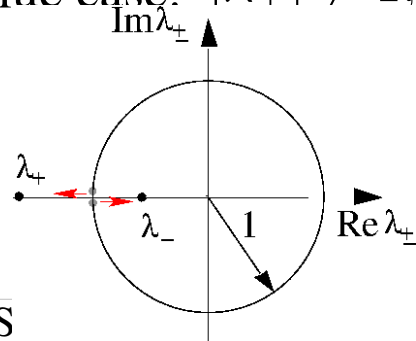

## Comments:

- ◆ As  $\kappa$  becomes stronger and stronger it is not necessarily the case that instability persists. There can be (typically) narrow ranges of stability within a mostly unstable range of parameters.
  - Example: Stability/instability bands of the Mathieu equation commonly studied in mathematical physics which is a special case of Hills' equation.
- ◆ Higher order regions of stability past the first instability band likely make little sense to exploit because they require higher field strength (to generate larger  $\kappa$ ) and generally lead to larger particle oscillations than for weaker fields below the first stability threshold.

# S6: Hill's Equation: Floquet's Theorem and the Phase-Amplitude Form of the Particle Orbit

## S6A: Introduction

In this section we consider **Hill's Equation**:

$$x''(s) + \kappa(s)x(s) = 0$$

subject to a **periodic** applied focusing function

$$\kappa(s + L_p) = \kappa(s)$$

$$L_p = \text{Lattice Period}$$

- ♦ Many results will also hold in more complicated form for a non-periodic  $\kappa(s)$ 
  - Results less clean in this case
  - (initial conditions not removable to same degree as periodic case)

## S6B: Floquet's Theorem

Floquet's Theorem (proof: see standard Mathematics and Mathematical Physics Texts)

The solution to Hill's Equation  $x(s)$  can be written in terms of two linearly independent solutions expressible as:

$$\begin{aligned}x_1(s) &= w(s)e^{i\mu s} & i &= \sqrt{-1} \\x_2(s) &= w(s)e^{-i\mu s} & \mu &= \frac{1}{2}\text{Tr } \mathbf{M}(s_i + L_p | s_i) = \cos \sigma_0 \\ & & &= \text{const} = \text{Characteristic Exponent}\end{aligned}$$

Where  $w(s)$  is a **periodic** function:

$$w(s + L_p) = w(s)$$

- ◆ Theorem as written only applies for  $\mathbf{M}$  with non-degenerate eigenvalues. But a similar theorem applies in the degenerate case.
- ◆ A similar theorem is also valid for non-periodic focusing functions
  - Expression not as simple but has analogous form

## S6C: Phase-Amplitude Form of Particle Orbit

As a consequence of [Floquet's Theorem](#), any (stable or unstable) nondegenerate solution to [Hill's Equation](#) can be expressed in [phase-amplitude](#) form as:

$$\begin{aligned}x(s) &= A(s) \cos \psi(s) & A(s) &= \text{Real-Valued Amplitude Function} \\A(s + L_p) &= A(s) & \psi(s) &= \text{Real-Valued Phase Function}\end{aligned}$$

- ◆ Have not done anything yet: replace one function  $x(s)$  by two  $A(s)$ ,  $\psi(s)$
- ◆ Floquet's theorem tells us we lose nothing in doing this

Derive equations of motion for  $A$ ,  $\psi$  by taking derivatives of the phase-amplitude form for  $x(s)$ :

$$x = A \cos \psi$$

$$x' = A' \cos \psi - A\psi' \sin \psi$$

$$x'' = A'' \cos \psi - 2A'\psi' \sin \psi - A\psi'' \sin \psi - A\psi'^2 \cos \psi$$

then substitute in [Hill's Equation](#) and isolate coefficients of  $\sin \psi$ ,  $\cos \psi$  :

$$x'' + \kappa x = [A'' + \kappa A - A\psi'^2] \cos \psi - [2A'\psi' + A\psi''] \sin \psi = 0$$

$$x'' + \kappa x = [A'' + \kappa A - A\psi'^2] \cos \psi - [2A'\psi' + A\psi''] \sin \psi = 0$$

We are *free to introduce an additional constraint* between  $A$  and  $\psi$ :

- Two functions  $A, \psi$  to represent one function  $x$  allows a constraint

Choose:

Eq. (1)  $2A'\psi' + A\psi'' = 0 \implies$  Coefficient of  $\sin \psi$  zero

Then to satisfy Hill's Equation for all  $\psi$ , the coefficient of  $\cos \psi$  must also vanish giving:

Eq. (2)  $A'' + \kappa A - A\psi'^2 = 0 \implies$  Coefficient of  $\cos \psi$  zero



Eq. (1) Analysis (coefficient of  $\sin \psi$ ):  $2A'\psi' + A\psi'' = 0$

Simplify:

$$2A'\psi' + A\psi'' = \frac{(A^2\psi')'}{A} = 0$$

Assume for moment:  
 $A \neq 0$

$$\implies (A^2\psi')' = 0$$

Will show later  
that this assumption  
met for all  $s$

Integrate once:

$$A^2\psi' = \text{const}$$

One commonly **rescales** the amplitude  $A(s)$  in terms of an auxiliary amplitude function  $w(s)$ :

$$A(s) = A_i w(s) \quad A_i = \text{const} = \text{Initial Amplitude}$$

such that

$$w^2\psi' \equiv 1$$

Note:

- ◆  $[[A_i]] = [[w]] = \text{sqrt(meters)}$
- ◆  $[[A]] = \text{meters}$  and  $[[A]] \neq [[A_i]]$

This equation can then be integrated to obtain the **phase-function** of the particle:

$$\psi(s) = \psi_i + \int_{s_i}^s \frac{d\tilde{s}}{w^2(\tilde{s})} \quad \psi_i = \text{const} = \text{Initial Phase}$$

$$w \neq 0$$

Eq. (2) Analysis (coefficient of  $\cos \psi$ ):  $A'' + \kappa A - A\psi'^2 = 0$

With the choice of amplitude rescaling,  $A = A_i w$  and  $w^2 \psi' = 1$ , Eq. (2) becomes:

$$w'' + \kappa w - \frac{1}{w^3} = 0$$

Floquet's theorem tells us that we are *free to restrict w to be a periodic solution*:

$$w(s + L_p) = w(s)$$

Reduced Expressions for  $x$  and  $x'$ :

Using  $A = A_i w$  and  $w^2 \psi' = 1$ :

$$x = A \cos \psi$$

$$x' = A' \cos \psi - A\psi' \sin \psi$$

$$\Rightarrow \begin{cases} x = A_i w \cos \psi \\ x' = A_i w' \cos \psi - \frac{A_i}{w} \sin \psi \end{cases}$$

Phase-Space form of orbit  
in phase-amplitude form

## S6D: Summary: Phase-Amplitude Form of Solution to Hill's Eqn

$$x(s) = A_i w(s) \cos \psi(s)$$

$$A_i = \text{const} = \text{Initial Amplitude}$$

$$x'(s) = A_i w'(s) \cos \psi(s) - \frac{A_i}{w(s)} \sin \psi(s)$$

$$\psi_i = \text{const} = \text{Initial Phase}$$

where  $w(s)$  and  $\psi(s)$  are **amplitude-** and **phase-functions** satisfying:

### Amplitude Equations

$$w''(s) + \kappa(s)w(s) - \frac{1}{w^3(s)} = 0$$

$$w(s + L_p) = w(s)$$

$$w(s) > 0$$

### Phase Equations

$$\psi'(s) = \frac{1}{w^2(s)}$$

$$\psi(s) = \psi_i + \int_{s_i}^s \frac{d\tilde{s}}{w^2(\tilde{s})}$$

$$\psi(s) = \psi_i + \Delta\psi(s)$$

Initial (  $s = s_i$  ) amplitude and phase are constrained by the particle initial conditions as:

$$x(s = s_i) = A_i w_i \cos \psi_i$$

$$x'(s = s_i) = A_i w'_i \cos \psi_i - \frac{A_i}{w_i} \sin \psi_i$$

or

$$A_i \cos \psi_i = x(s = s_i) / w_i$$

$$w_i \equiv w(s = s_i)$$

$$A_i \sin \psi_i = x(s = s_i)w'_i - x'(s = s_i)w_i$$

$$w'_i \equiv w'(s = s_i)$$

## S6E: Points on the Phase-Amplitude Formulation

1)  $w(s)$  can be taken as **positive definite**

$$w(s) > 0$$

**/// Proof:** Sign choices in  $w$ :

Let  $w(s)$  be positive at some point. Then the equation:

$$w'' + \kappa w - \frac{1}{w^3} = 0$$

Insures that  $w$  can never vanish or change sign. This follows because whenever  $w$  becomes small,  $w'' \simeq 1/w^3 \gg 0$  can become arbitrarily large to turn  $w$  before it reaches zero. Thus, to fix phases, we conveniently require that  $w > 0$ .

**///**

- ◆ Proof verifies assumption made in analysis that  $A = A_i w \neq 0$
- ◆ Conversely, one could choose  $w$  negative and it would always remain negative for analogous reasons. This choice is *not* commonly made.
- ◆ Sign choice removes ambiguity in relating initial conditions  $x(s_i)$ ,  $x'(s_i)$  to  $A_i$ ,  $\psi_i$

## 2) $w(s)$ is a **unique periodic function**

- Can be proved using a connection between  $w$  and the principal orbit functions  $C$  and  $S$  (see: **Appendix A** and **S7**)
- $w(s)$  can be regarded as a special, periodic function describing the lattice focusing function  $\kappa(s)$

## 3) The **amplitude parameters**

$$w_i = w(s = s_i)$$

$$w'_i = w'(s_i)$$

depend *only* on the periodic lattice properties and are *independent* of the particle initial conditions  $x(s_i)$ ,  $x'(s_i)$

## 4) The change in phase

$$\Delta\psi(s) = \int_{s_i}^s \frac{d\tilde{s}}{w^2(\tilde{s})}$$

depends on the choice of initial condition  $s_i$ . However, the **phase-advance** through one lattice period  $\Delta\psi(s_i + L_p) = \int_{s_i}^{s_i + L_p} \frac{d\tilde{s}}{w^2(\tilde{s})}$

is independent of  $s_i$  since  $w$  is a periodic function with period  $L_p$

- ◆ Will show later that (see **S6F**)

$$\Delta\psi(s_i + L_p) \equiv \sigma_0$$

is the undepressed phase advance of particle oscillations. This will help us interpret the lattice focusing strength.

5)  $w(s)$  has dimensions  $[[w]] = \text{Sqrt}[\text{meters}]$

- ◆ Can prove inconvenient in applications and motivates the use of an alternative “betatron” function  $\beta$

$$\beta(s) \equiv w^2(s)$$

with dimension  $[[\beta]] = \text{meters}$  (see: **S7** and **S8**)

6) On the surface, what we have done: Transform the **linear Hill's Equation** to a form where a solution to **nonlinear axillary equations** for  $w$  and  $\psi$  are needed via the **phase-amplitude method** seems insane ..... **why do it?**

- ◆ Method will help identify the useful Courant-Snyder invariant which will aid interpretation of the dynamics (see: **S7**)
- ◆ Decoupling of initial conditions in the phase-amplitude method will help simplify understanding of bundles of particles in the distribution

## S6F: Relation between Principal Orbit Functions and Phase-Amplitude Form Orbit Functions

The **transfer matrix**  $\mathbf{M}$  of the particle orbit can be expressed in terms of the principal orbit functions  $C$  and  $S$  as (see: **S4**):

$$\begin{bmatrix} x(s) \\ x'(s) \end{bmatrix} = \mathbf{M}(s|s_i) \cdot \begin{bmatrix} x(s_i) \\ x'(s_i) \end{bmatrix} = \begin{bmatrix} C(s|s_i) & S(s|s_i) \\ C'(s|s_i) & S'(s|s_i) \end{bmatrix} \cdot \begin{bmatrix} x(s_i) \\ x'(s_i) \end{bmatrix}$$

Use of the **phase-amplitude forms** and some algebra identifies (see problem sets):

$$\begin{aligned} C(s|s_i) &= \frac{w(s)}{w_i} \cos \Delta\psi(s) - w'_i w(s) \sin \Delta\psi(s) \\ S(s|s_i) &= w_i w(s) \sin \Delta\psi(s) \\ C'(s|s_i) &= \left( \frac{w'(s)}{w_i} - \frac{w'_i}{w(s)} \right) \cos \Delta\psi(s) - \left( \frac{1}{w_i w(s)} + w'_i w'(s) \right) \sin \Delta\psi(s) \\ S'(s|s_i) &= \frac{w_i}{w(s)} \cos \Delta\psi(s) + w_i w'(s) \sin \Delta\psi(s) \\ \Delta\psi(s) &\equiv \int_{s_i}^s \frac{d\tilde{s}}{w^2(\tilde{s})} \qquad w_i \equiv w(s = s_i) \\ &\qquad\qquad\qquad w'_i \equiv w'(s = s_i) \end{aligned}$$

// **Aside:** Some steps in derivation:  $\psi = \psi_i + \Delta\psi$   $\Delta\psi(s = s_i) = 0$

$$x = A_i w \cos \psi = A_i w \cos(\Delta\psi + \psi_i) \quad (*)$$

$$x' = A_i w' \cos \psi - \frac{A_i}{w} \sin \psi = A_i w' \cos(\Delta\psi + \psi_i) - \frac{A_i}{w} \sin(\Delta\psi + \psi_i)$$

Initially:  $x_i = A_i w \cos \psi_i$

$$x'_i = A_i w'_i \cos \psi_i - \frac{A_i}{w_i} \sin \psi_i = w'_i \frac{x_i}{w_i} - \frac{A_i}{w_i} \sin \psi_i$$

Or:

$$\begin{aligned} A_i \cos \psi_i &= x_i / w_i \\ A_i \sin \psi_i &= x_i w'_i - x'_i w_i \end{aligned} \quad (2)$$

Use trigonometric formulas:

$$\begin{aligned} \cos(\Delta\psi + \psi_i) &= \cos \Delta\psi \cos \psi_i - \sin \Delta\psi \sin \psi_i \\ \sin(\Delta\psi + \psi_i) &= \sin \Delta\psi \cos \psi_i + \cos \Delta\psi \sin \psi_i \end{aligned} \quad (1)$$

Insert (1) and (2) in (\*) for x and then rearrange and compare to  $x = C x_i + S x'_i$

to obtain:  $[\dots] = C(s|s_i)$   $[\dots] = S(s|s_i)$

$$\mathbf{x} = \left[ \frac{w}{w_i} \cos \Delta\psi - w'_i w \sin \Delta\psi \right] x_i + [w_i w \sin \Delta\psi] x'_i$$

Add steps and repeat with particle angle  $x'$  to complete derivation

//



/// **Aside:** Alternatively, it can be shown (see: [Appendix A](#)) that  $w(s)$  can be related to the principal orbit functions calculated over one Lattice period by:

$$w^2(s) = \beta(s) = \sin \sigma_0 \frac{S(s|s_i)}{S(s_i + L_p|s_i)} + \frac{S(s_i + L_p|s_i)}{\sin \sigma_0} \left[ C(s|s_i) + \frac{\cos \sigma_0 - C(s|s_i)}{S(s_i + L_p|s_i)} S(s|s_i) \right]^2$$

$$\sigma_0 \equiv \int_{s_i}^{s_i + L_p} \frac{d\tilde{s}}{w^2(\tilde{s})}$$

The formula for  $\sigma_0$  in terms of principal orbit functions is useful:

- ◆  $\sigma_0$  (phase advance, see: [S6G](#)) is often specified for the lattice and the focusing function  $\kappa(s)$  is tuned to achieve the specified value
- ◆ Shows that  $w(s)$  can be constructed from two principal orbit integrations over one lattice period
  - Integrations must generally be done numerically for  $C$  and  $S$
  - No root finding required for initial conditions to construct periodic  $w(s)$
  - $s_i$  can be anywhere in the lattice period and  $w(s)$  will be independent of the specific choice of  $s_i$

- ♦ The form of  $w^2(s)$  suggests an underlying **Courant-Snyder Invariant** (see: **S7** and **Appendix A**)
- ♦  $w^2 = \beta$  can be applied to calculate max beam particle excursions in the absence of space-charge effects (see: **S8**)
  - Useful in machine design
  - Exploits **Courant-Snyder Invariant**
- ♦ Techniques to map lattice functions from one point in lattice to another are also presented in **Appendix A** and **S7C**
  - Include efficient Lee Algebra derived expressions in **S7C**

///

## S6G: Undepressed Particle Phase Advance

We can now concretely connect  $\sigma_0$  for a stable orbit to the change in particle oscillation phase  $\Delta\psi$  through one lattice period:

From **S5D**:

$$\cos \sigma_0 \equiv \frac{1}{2} \text{Tr } \mathbf{M}(s_i + L_p | s_i)$$

Apply the principal orbit representation of  $\mathbf{M}$

$$\mathbf{M} \equiv \begin{bmatrix} C & S \\ C' & S' \end{bmatrix}$$

$$\text{Tr } \mathbf{M}(s_i + L_p | s_i) = C(s_i + L_p | s_i) + S'(s_i + L_p | s_i)$$

and use the phase-amplitude identifications of  $C$  and  $S'$  calculated in **S6F**:

$$\begin{aligned} \frac{1}{2} \text{Tr } \mathbf{M}(s_i + L_p | s_i) &= \frac{1}{2} \left[ \frac{w(s_i + L_p)}{w_i} + \frac{w_i}{w(s_i + L_p)} \right] \cos \Delta\psi(s_i + L_p) \\ &+ \frac{1}{2} [w_i w'(s_i + L_p) - w'_i w(s_i + L_p)] \sin \Delta\psi(s_i + L_p) \end{aligned}$$

By periodicity:

$$\begin{aligned} w(s_i + L_p) &= w(s_i) = w_i \\ w'(s_i + L_p) &= w'(s_i) = w'_i \end{aligned} \quad \Longrightarrow \quad \begin{aligned} \text{coefficient of } \cos \Delta\psi &= 1 \\ \text{coefficient of } \sin \Delta\psi &= 0 \end{aligned}$$

Applying these results gives:

$$\cos \sigma_0 = \cos \Delta\psi(s_i + L_p) = \frac{1}{2} \text{Tr } \mathbf{M}(s_i + L_p | s_i)$$

Thus,  $\sigma_0$  is identified as the **phase advance** of a stable particle orbit through one lattice period:

$$\sigma_0 = \Delta\psi(s_i + L_p) = \int_{s_i}^{s_i + L_p} \frac{ds}{w^2(s)}$$

- ◆ Again verifies that  $\sigma_0$  is independent of  $s_i$  since  $w(s)$  is periodic with period  $L_p$
- ◆ The **stability criterion** (see: **S5**)

$$\frac{1}{2} |\text{Tr } \mathbf{M}(s_i + L_p | s_i)| = |\cos \sigma_0| \leq 1$$

is concretely connected to the particle phase advance through one lattice period providing a useful physical interpretation

Consequence:

**Any periodic lattice with undepressed phase advance satisfying**

$$\sigma_0 < \pi / \text{period} = 180^\circ / \text{period}$$

**will have stable single particle orbits.**

## Discussion:

The **phase advance**  $\sigma_0$  is an extremely useful dimensionless measure to characterize the focusing strength of a periodic lattice. Much of conventional accelerator physics centers on focusing strength and the suppression of resonance effects. The phase advance is a natural parameter to employ in many situations to allow ready interpretation of results in a generalizable manner.

We present **phase advance formulas** for several simple classes of lattices to help build intuition on focusing strength:

### 1) Continuous Focusing

### 2) Periodic Solenoidal Focusing

### 3) Periodic Quadrupole Doublet Focusing

- FODO Quadrupole Limit

◆ Lattices analyzed as “hard-edge” with piecewise-constant  $\kappa(s)$  and lattice period  $L_p$

◆ Results are summarized only with derivations guided in the problem sets.

### 4) Thin Lens Limits

- Useful for analysis of scaling properties

One of these  
will be derived  
in the problem sets

# 1) Continuous Focusing $x'' + \kappa_x x = x'' + k_{\beta 0}^2 x = 0$

“Lattice period”  $L_p$  is an arbitrary length for phase accumulation

$$\kappa(s) = k_{\beta 0}^2 = \text{const} > 0$$

Parameters:

$L_p$  = Lattice Period

$k_{\beta 0}^2$  = Strength

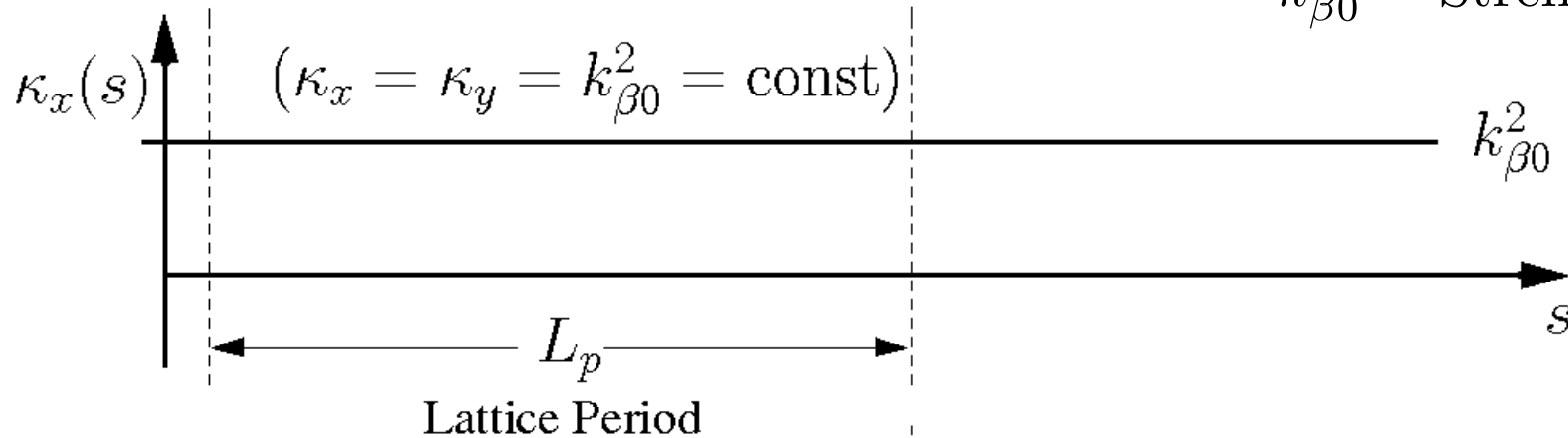

Apply phase advance formulas:

$$w'' + k_{\beta 0}^2 w - \frac{1}{w^3} = 0 \quad \Rightarrow$$

$$w = \frac{1}{\sqrt{k_{\beta 0}}}$$

$$\sigma_0 = k_{\beta 0} L_p$$

$$\sigma_0 = \int_{s_i}^{s_i + L_p} \frac{ds}{w^2} = k_{\beta 0} L_p$$

◆ Always stable

- Energy cannot pump into or out of particle orbit

## Rescaled Principal Orbit Evolution:

$$L_p = 0.5 \text{ m}$$
$$\sigma_0 = \pi/3 = 60^\circ$$
$$k_{\beta 0} = (\pi/6) \text{ rad/m}$$

Cosine-Like

1:  $x(0) = 1 \text{ mm}$   
 $x'(0) = 0 \text{ mrad}$

Sine-Like

2:  $x(0) = 0 \text{ mm}$   
 $x'(0) = 1 \text{ mrad}$

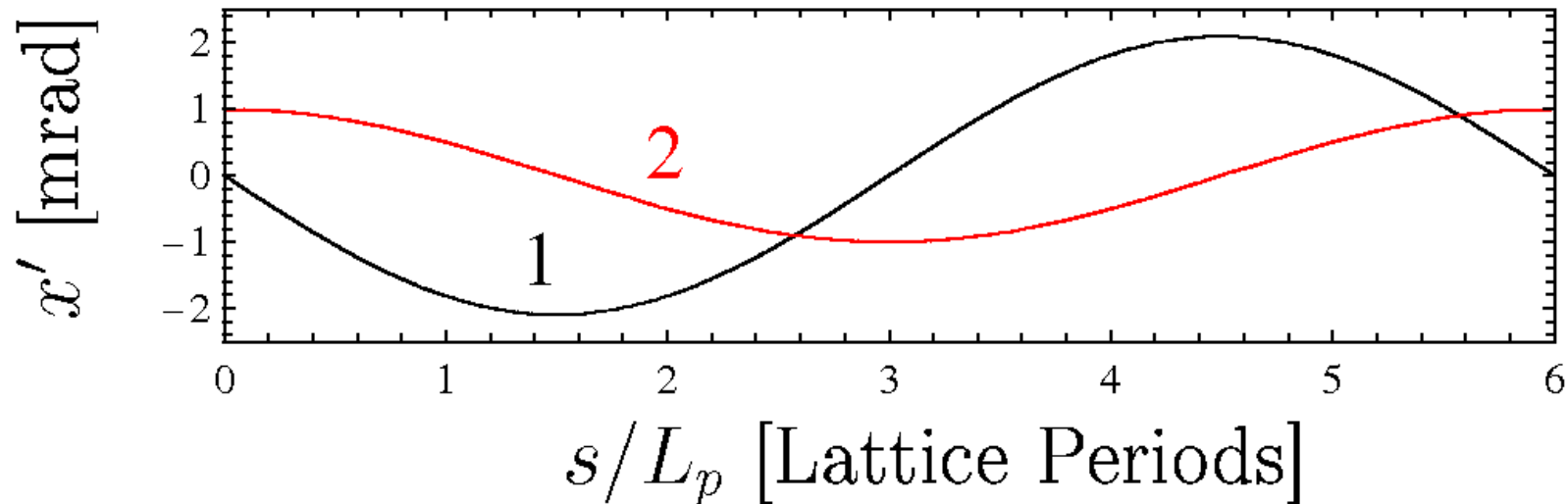
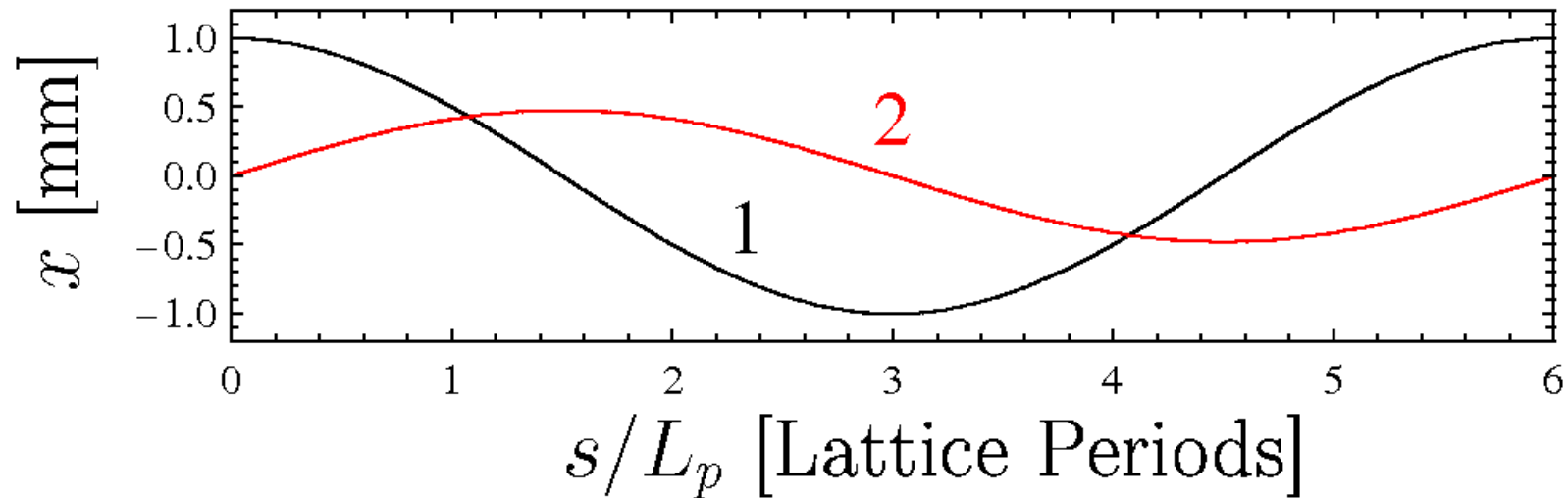

## Phase-Space Evolution (see also S7):

- ◆ Phase-space ellipse stationary and aligned along  $x, x'$  axes for continuous focusing

$$w = \sqrt{1/k_{\beta 0}} = \text{const}$$

$$w' = 0$$

$$\gamma = \frac{1}{w^2} = k_{\beta 0} = \text{const}$$

$$\alpha = -ww' = 0$$

$$\beta = w^2 = 1/k_{\beta 0} = \text{const}$$

$$k_{\beta 0}x^2 + x'^2/k_{\beta 0} = \epsilon = \text{const}$$

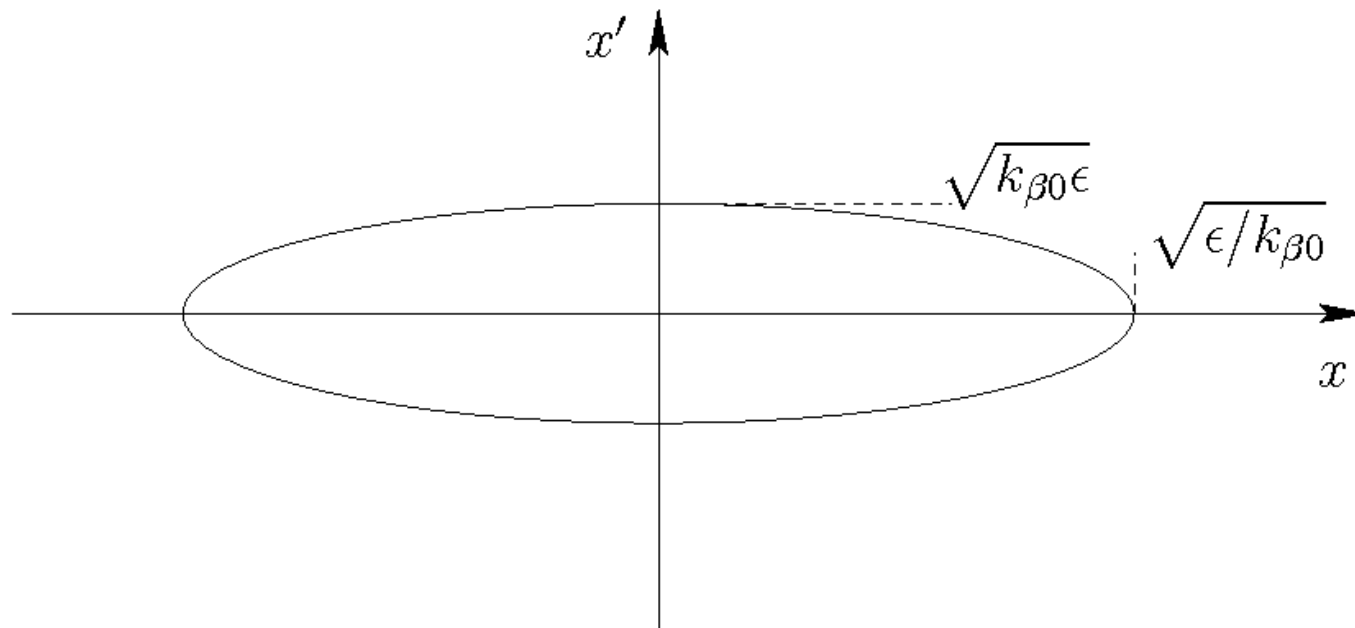



## 2) Periodic Solenoidal Focusing

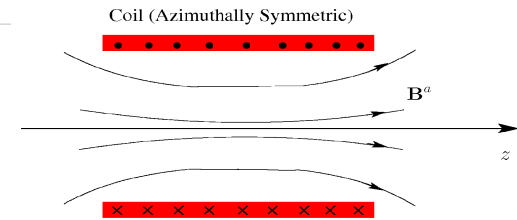

$$x''(s) - \frac{B'_{z0}(s)}{2[B\rho]} y(s) - \frac{B_{z0}(s)}{[B\rho]} y'(s) = 0$$

$$y''(s) + \frac{B'_{z0}(s)}{2[B\rho]} x(s) + \frac{B_{z0}(s)}{[B\rho]} x'(s) = 0$$

$$B_{z0}(s) = B_z(r=0, z=s)$$

= On-Axis Field

Results are interpreted in the rotating Larmor frame (see **Solenoid Focusing**)

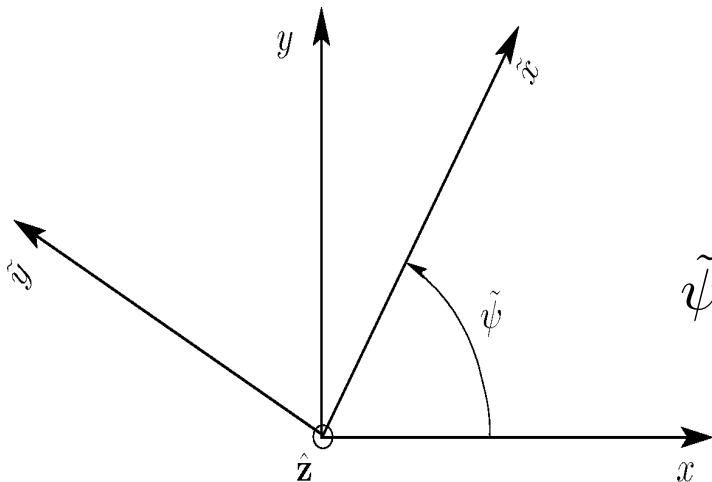

$$\tilde{x} = x \cos \tilde{\psi}(s) + y \sin \tilde{\psi}(s)$$

$$\tilde{y} = -x \sin \tilde{\psi}(s) + y \cos \tilde{\psi}(s)$$

$$\tilde{\psi}(s) = - \int_{s_i}^s d\bar{s} k_L(\bar{s}) \quad k_L(s) \equiv \frac{B_{z0}(s)}{2[B\rho]}$$

= Larmor Wavenumber

$$[B\rho] \equiv \frac{p}{q} \simeq \frac{\gamma_b \beta_b m c}{q} \equiv \text{Rigidity}$$

$$\tilde{x}''(s) + \kappa(s) \tilde{x}(s) = 0$$

$$\tilde{y}''(s) + \kappa(s) \tilde{y}(s) = 0$$

$$\kappa(s) = \left( \frac{B_0(s)}{2[B\rho]} \right)^2 = (k_L)^2$$

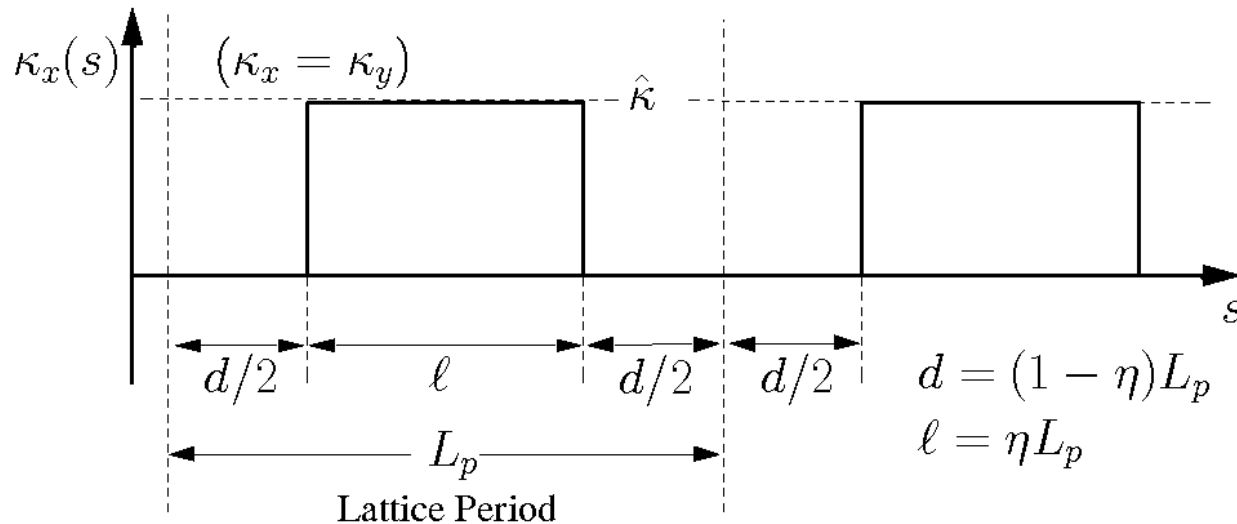

### Parameters:

$L_p$  = Lattice Period

$\eta \in (0, 1]$  = Occupancy

$\hat{\kappa}$  = Strength

### Characteristics:

$\eta L_p$  = Optic Length

$(1 - \eta)L_p$  = Drift Length

Calculation (in problem sets) gives:

$$\cos \sigma_0 = \cos(2\Theta) - \frac{1 - \eta}{\eta} \Theta \sin(2\Theta) \quad \Theta \equiv \frac{\eta}{2} \sqrt{\hat{\kappa}} L_p$$

- ♦ Can be unstable when  $\hat{\kappa}$  becomes large
  - Energy can pump into or out of particle orbit

# Rescaled Larmor-Frame **Principal Orbit Evolution** Solenoid Focusing:

$$L_p = 0.5 \text{ m}$$

$$\sigma_0 = \pi/3 = 60^\circ \quad (\kappa = 8.558 \text{ m}^{-2})$$

$$\eta = 0.5$$

Cosine-Like

1:  $\tilde{x}(0) = 1 \text{ mm}$

$\tilde{x}'(0) = 0 \text{ mrad}$

Sine-Like

2:  $\tilde{x}(0) = 0 \text{ mm}$

$\tilde{x}'(0) = 1 \text{ mrad}$

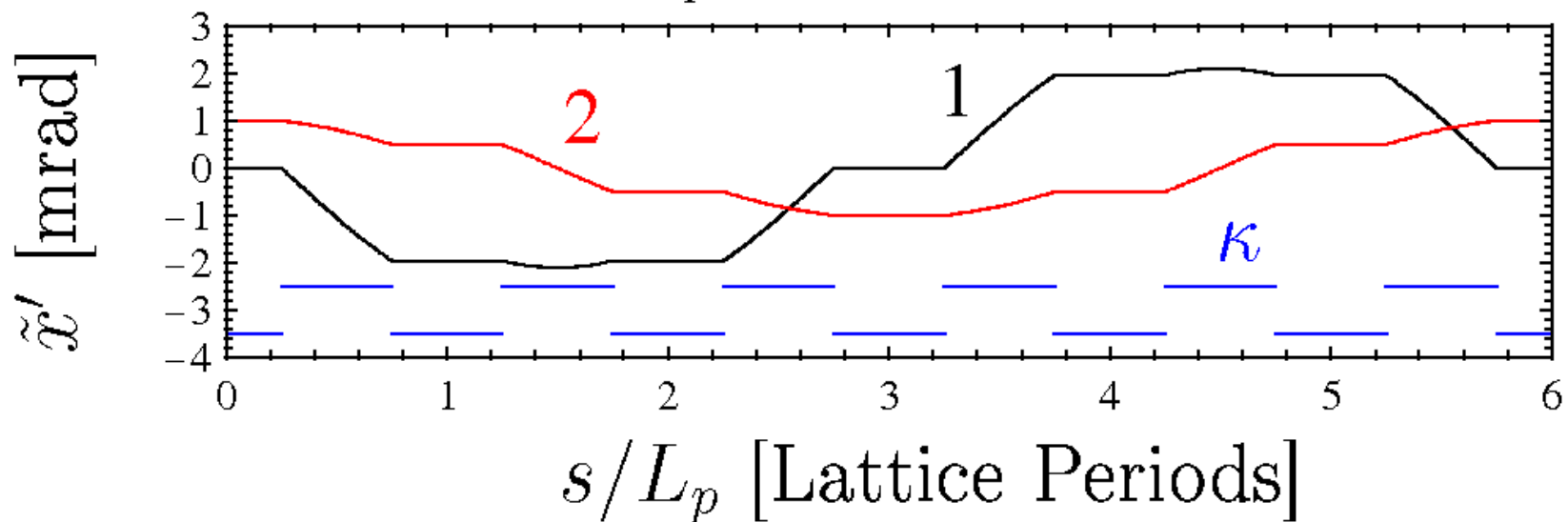
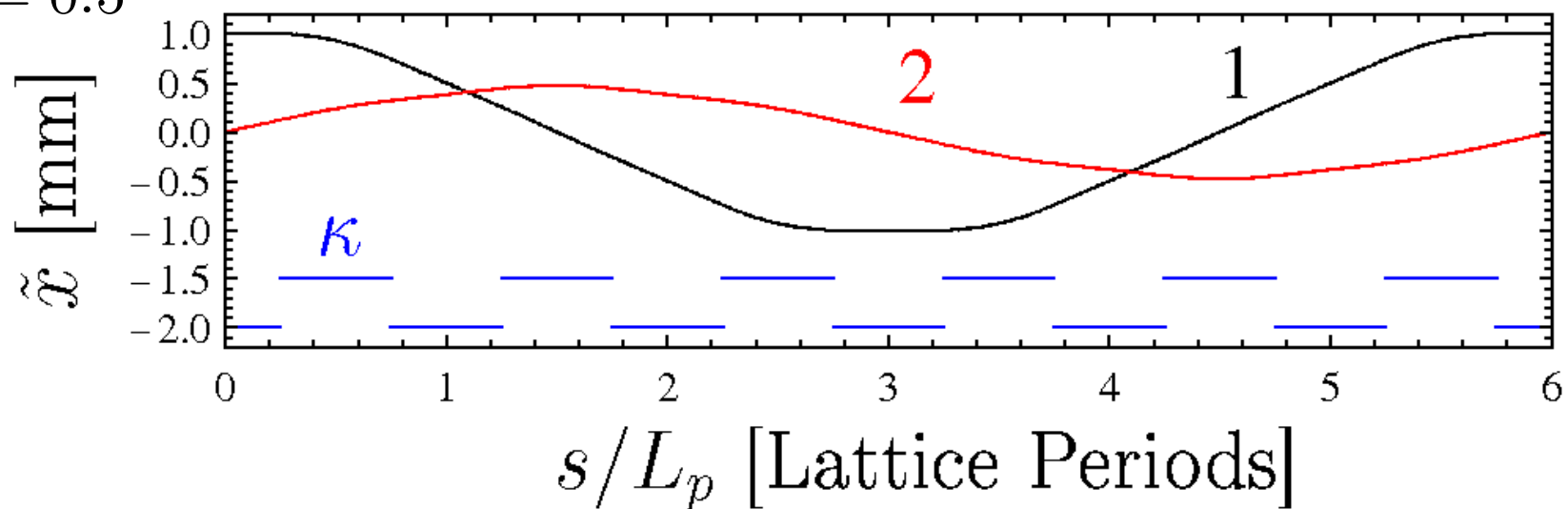

◆ Principal orbits in  $\tilde{y} - \tilde{y}'$  phase-space are identical

## Phase-Space Evolution in the Larmor frame (see also: S7):

- Phase-Space ellipse rotates and evolves in periodic lattice

$\tilde{y} - \tilde{y}'$  phase-space properties same as in  $\tilde{x} - \tilde{x}'$

- Phase-space structure in  $x-x'$ ,  $y-y'$  phase space is complicated

$$\gamma \tilde{x}^2 - 2\alpha \tilde{x} \tilde{x}' + \beta \tilde{x}'^2 = \epsilon = \text{const}$$

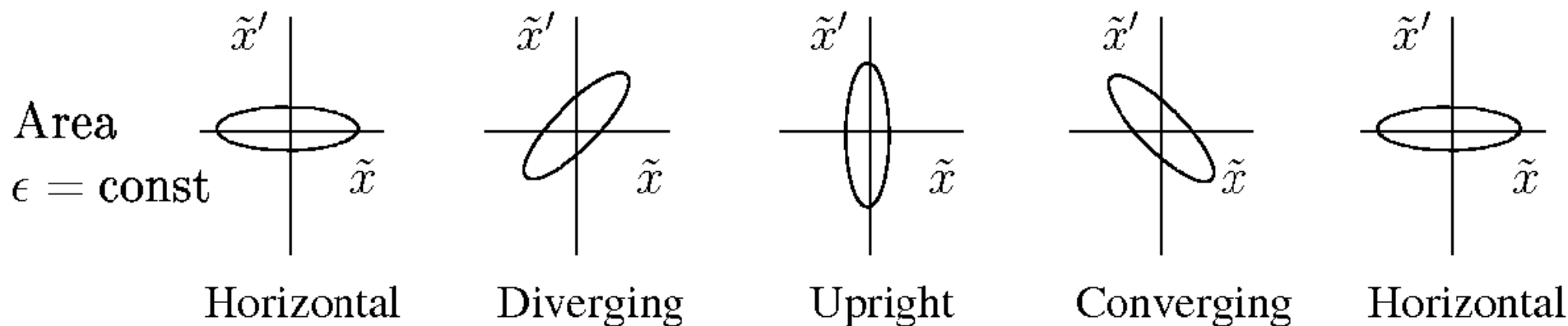
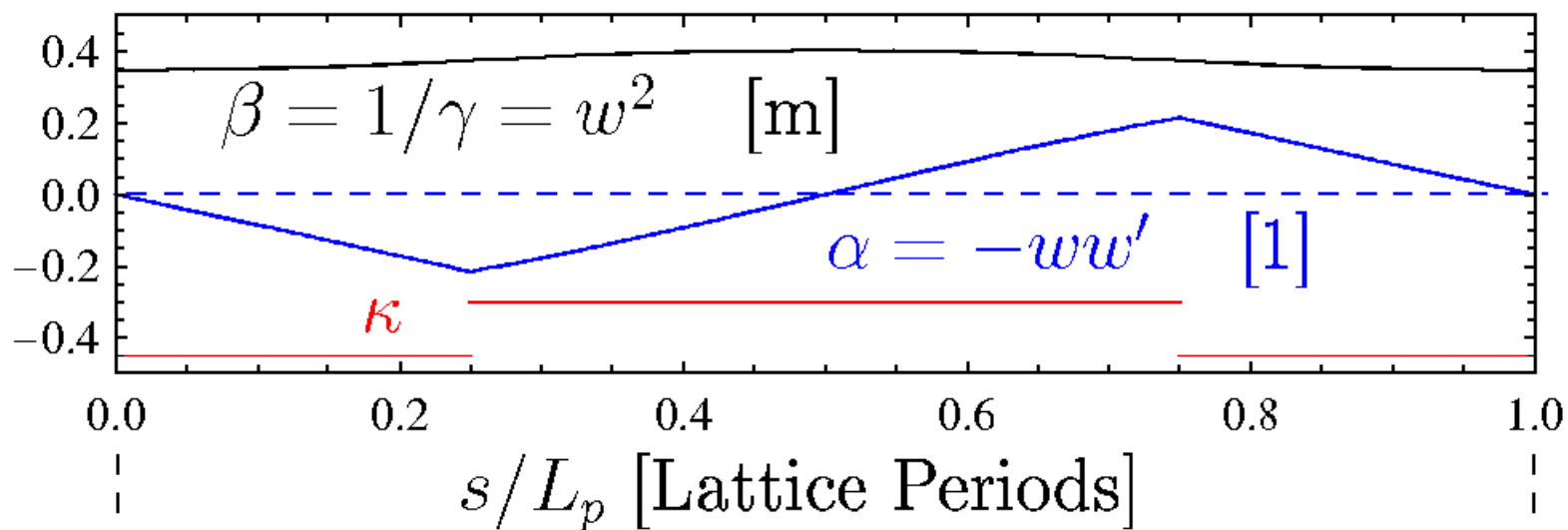

## Comments on periodic solenoid results:

- ◆ Larmor frame analysis greatly simplifies results
  - 4D coupled orbit in  $x-x'$ ,  $y-y'$  phase-space will be much more intricate in structure
- ◆ Phase-Space ellipse rotates and evolves in periodic lattice
- ◆ Periodic structure of lattice changes orbits from simple harmonic

### 3) Periodic Quadrupole FODO Lattice

$$x''(s) + \kappa(s)x(s) = 0$$

$$y''(s) - \kappa(s)y(s) = 0$$

For a magnetic quadrupole, we have

$$\kappa(s) = \frac{qG(s)}{m\gamma_b\beta_b c} = \frac{G(s)}{[B\rho]}$$

$$G(s) = \left. \frac{\partial B_x^a}{\partial y} \right|_{r=0} = \left. \frac{\partial B_y^a}{\partial x} \right|_{r=0} = \frac{B_q}{r_p}$$

= Field Gradient

$$[B\rho] \equiv \frac{p}{q} \simeq \frac{\gamma_b\beta_b mc}{q} \equiv \text{Rigidity}$$

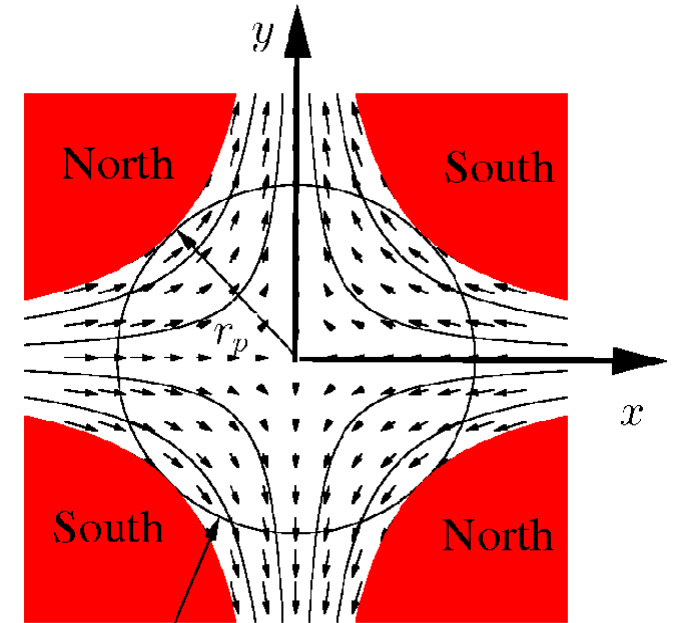

Conducting Beam Pipe:  $r = r_p$   
Poles:  $xy = \pm \frac{r_p^2}{2}$

$B_p$  = Pole Tip Field

$r_p$  = Clear Bore Aperture

Parameters:

$L_p =$  Lattice Period  
 $\eta \in (0, 1] =$  Occupancy  
 $\hat{\kappa} =$  Strength

Characteristics:

$\eta L_p/2 = \ell =$  F/D Len  
 $(1 - \eta)L_p/2 = d =$  Drift Len

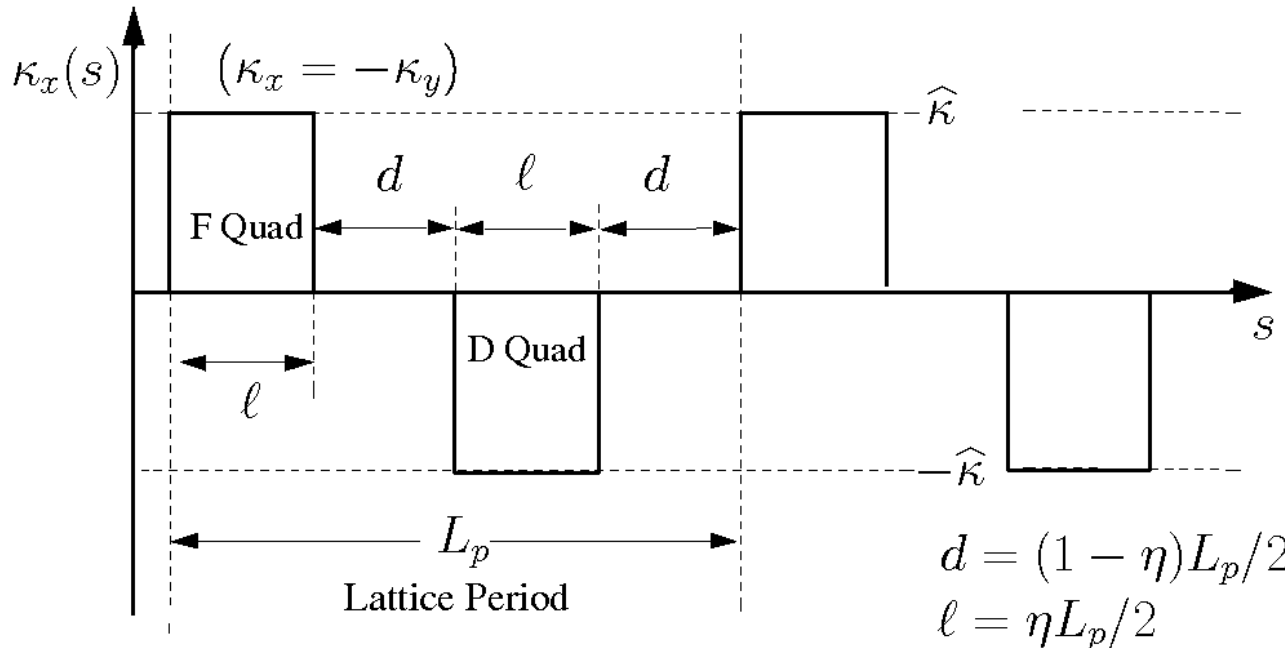

$$d = (1 - \eta)L_p/2$$

$$\ell = \eta L_p/2$$

Phase advance formula (see problem sets) reduces to:

$$\cos \sigma_0 = \cos \Theta \cosh \Theta + \frac{1 - \eta}{\eta} \Theta (\cos \Theta \sinh \Theta - \sin \Theta \cosh \Theta) - \frac{(1 - \eta)^2}{2\eta^2} \Theta^2 \sin \Theta \sinh \Theta$$

$$\Theta \equiv \frac{\eta}{2} \sqrt{|\hat{\kappa}|} L_p$$

Analysis shows FODO provides stronger focus for same integrated field gradients than asymmetric doublet (see following) due to symmetry

# Rescaled Principal Orbit Evolution FODO Quadrupole:

$$L_p = 0.5 \text{ m}$$

$$\sigma_0 = \pi/3 = 60^\circ \quad (\kappa = 39.24 \text{ m}^{-2})$$

$$\eta = 0.5$$

Cosine-Like

Sine-Like

1:  $x(0) = 1 \text{ mm}$

2:  $x(0) = 0 \text{ mm}$

$x'(0) = 0 \text{ mrad}$

$x'(0) = 1 \text{ mrad}$

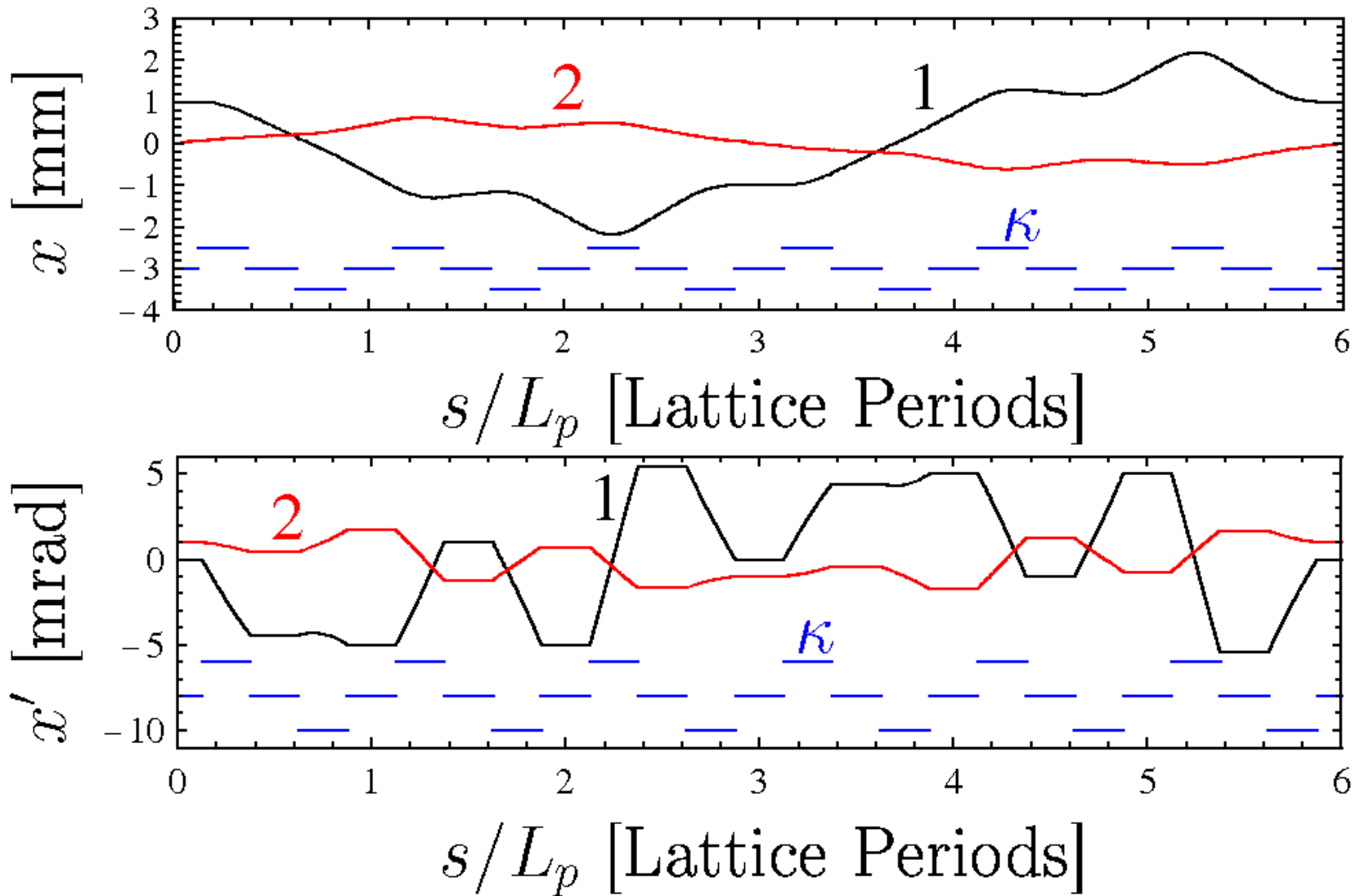



# Phase-Space Evolution (see also: S7):

$$\gamma x^2 - 2\alpha x x' + \beta x'^2 = \epsilon = \text{const}$$

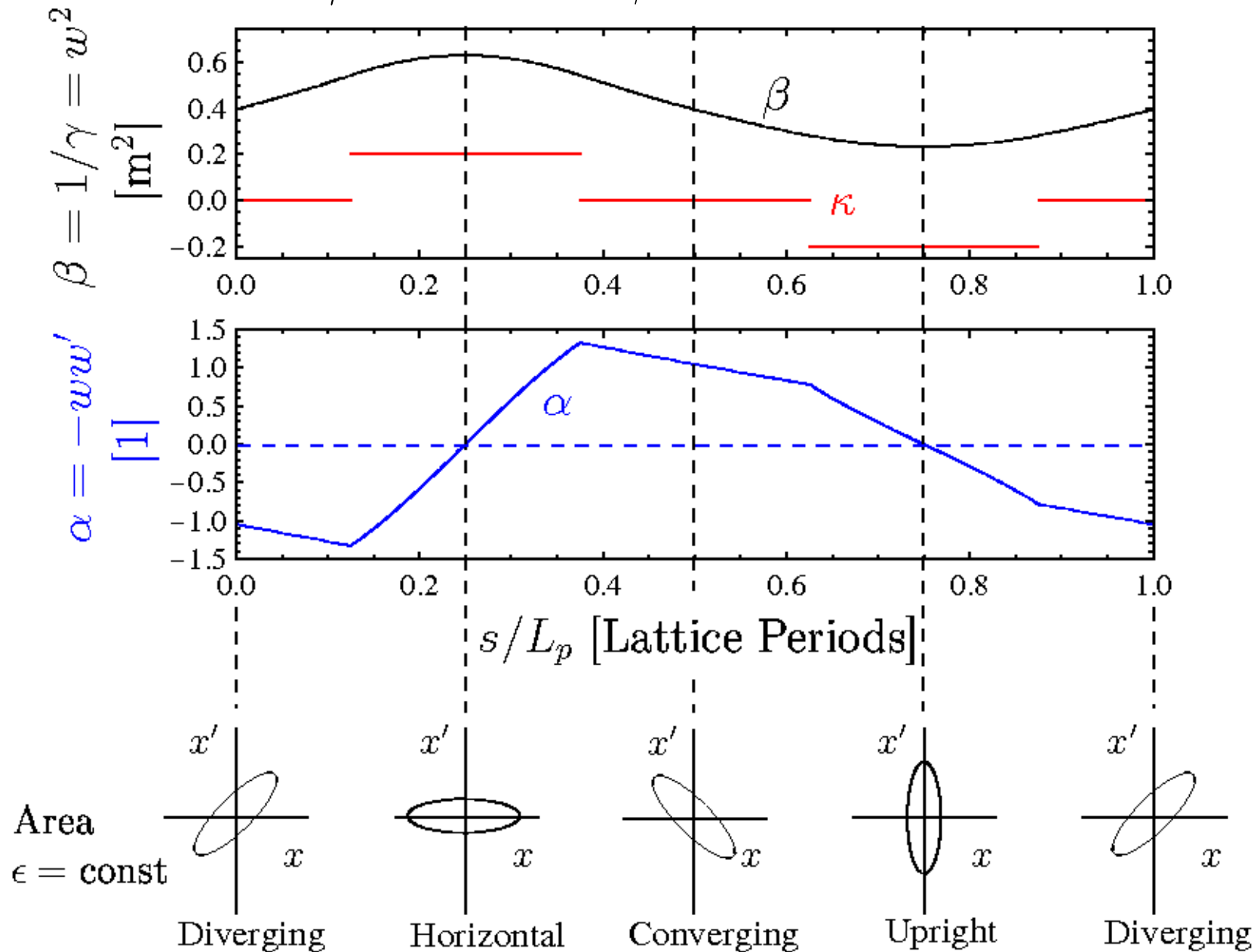

## Comments on periodic FODO quadrupole results:

- ◆ Phase-Space ellipse rotates and evolves in periodic lattice
  - Evolution more intricate for Alternating Gradient (AG) focusing than for solenoidal focusing in the Larmor frame
- ◆ Harmonic content of orbits larger for AG focusing than solenoidal focusing
- ◆ Orbit and phase space evolution analogous in  $y$ - $y'$  plane
  - Simply related by an shift in  $s$  of the lattice

## Extra: FODO drift symmetry relaxed: Periodic Quadrupole Doublet Focusing

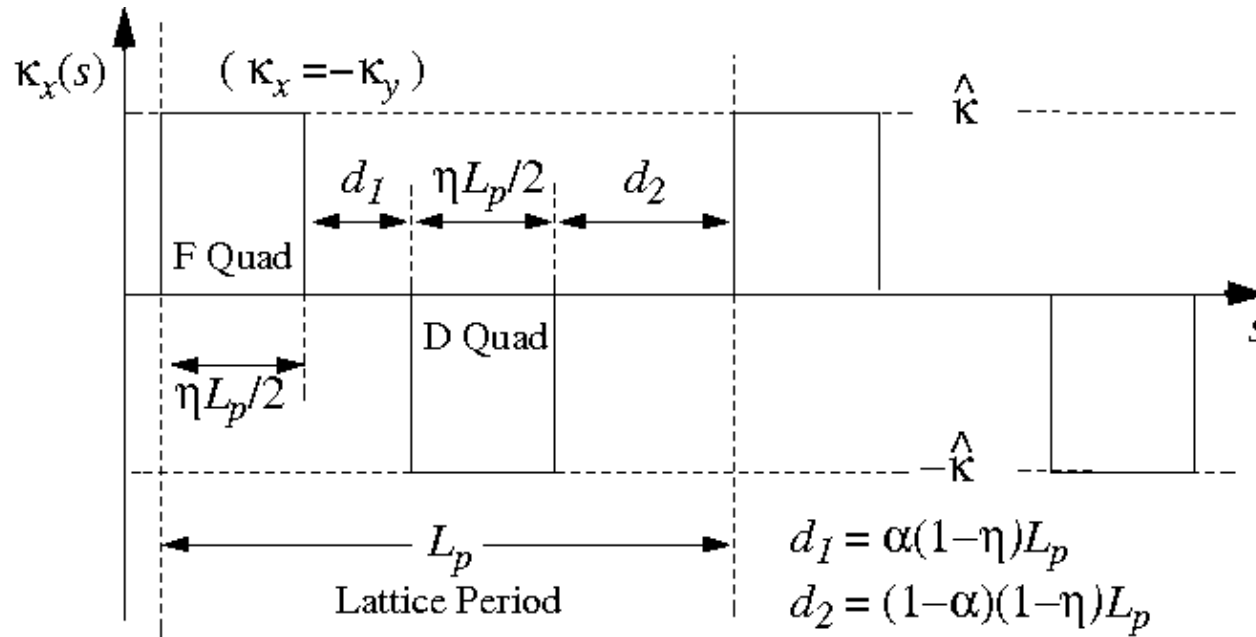

### Parameters:

$L_p$  = Lattice Period  
 $\eta \in (0, 1]$  = Occupancy  
 $\alpha \in [0, 1]$  = Syncopation  
 $\hat{\kappa}$  = Strength

### Characteristics:

$\eta L_p/2$  = F/D Len  
 $\alpha(1 - \eta)L_p$  = Drift Len  $d_1$   
 $(1 - \alpha)(1 - \eta)L_p$  = Drift Len  $d_2$

Calculation gives:

$$\cos \sigma_0 = \cos \Theta \cosh \Theta + \frac{1 - \eta}{\eta} \Theta (\cos \Theta \sinh \Theta - \sin \Theta \cosh \Theta) - 2\alpha(1 - \alpha) \frac{(1 - \eta)^2}{\eta^2} \Theta^2 \sin \Theta \sinh \Theta$$

$$\Theta \equiv \frac{\eta}{2} \sqrt{|\hat{\kappa}|} L_p$$

♦ Can be unstable when  $\hat{\kappa}$  becomes large

- Energy can pump into or out of particle orbit

## Comments on Parameters:

- ◆ The “syncopation” parameter  $\alpha$  measures how close the Focusing (F) and DeFocusing (D) quadrupoles are to each other in the lattice

$$\alpha \in [0, 1] \quad \begin{array}{l} \alpha = 0 \\ \alpha = 1 \end{array} \quad \Longrightarrow \quad \begin{array}{l} d_1 = 0 \\ d_1 = (1 - \eta)L_p \end{array} \quad \begin{array}{l} d_2 = (1 - \eta)L_p \\ d_2 = 0 \end{array}$$

The range  $\alpha \in [1/2, 1]$  can be mapped to  $\alpha \in [0, 1/2]$  by simply relabeling quantities. Therefore, we can take:

$$\alpha \in [0, 1/2]$$

- ◆ The special case of a doublet lattice with  $\alpha = 1/2$  corresponds to equal drift lengths between the F and D quadrupoles and is called a **FODO lattice**

$$\alpha = 1/2 \quad \Longrightarrow \quad d_1 = d_2 \equiv d = (1 - \eta)L_p/2$$

Phase advance constraint will be derived for FODO case in problems (algebra much simpler than doublet case)

Using these results, plot the **Field Gradient** and **Integrated Gradient** for quadrupole doublet focusing needed for  $\sigma_0 = 80^\circ$  per lattice period

$$\text{Gradient} \sim |\hat{\kappa}| L_p^2 \sim \hat{G}$$

$$\text{Integrated Gradient} \sim \eta |\hat{\kappa}| L_p^2 / 2 \sim \hat{G} \ell$$

$\sigma_0 = 80^\circ$  / (Lattice Period) Quadrupole Doublet

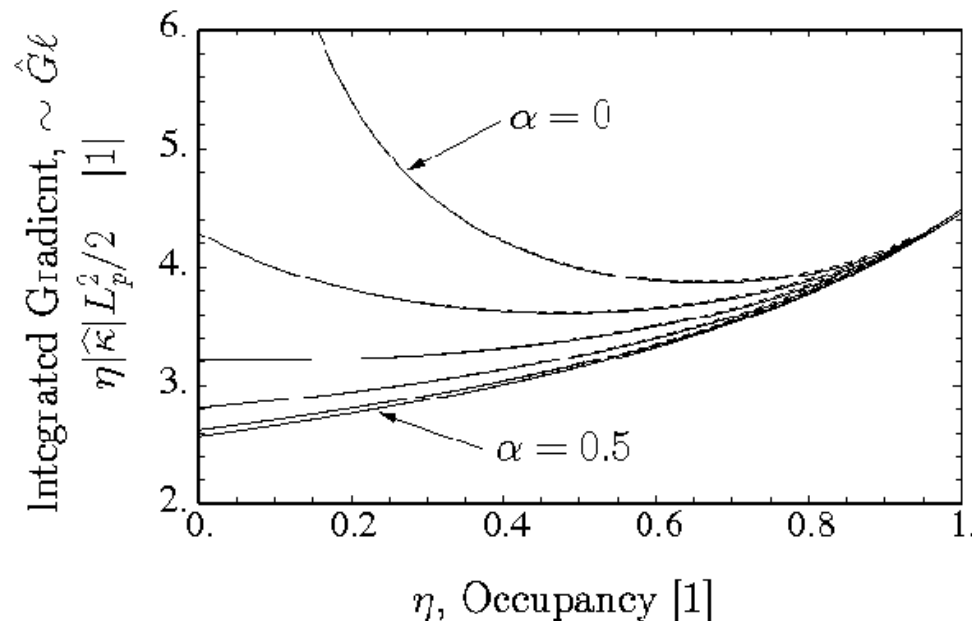
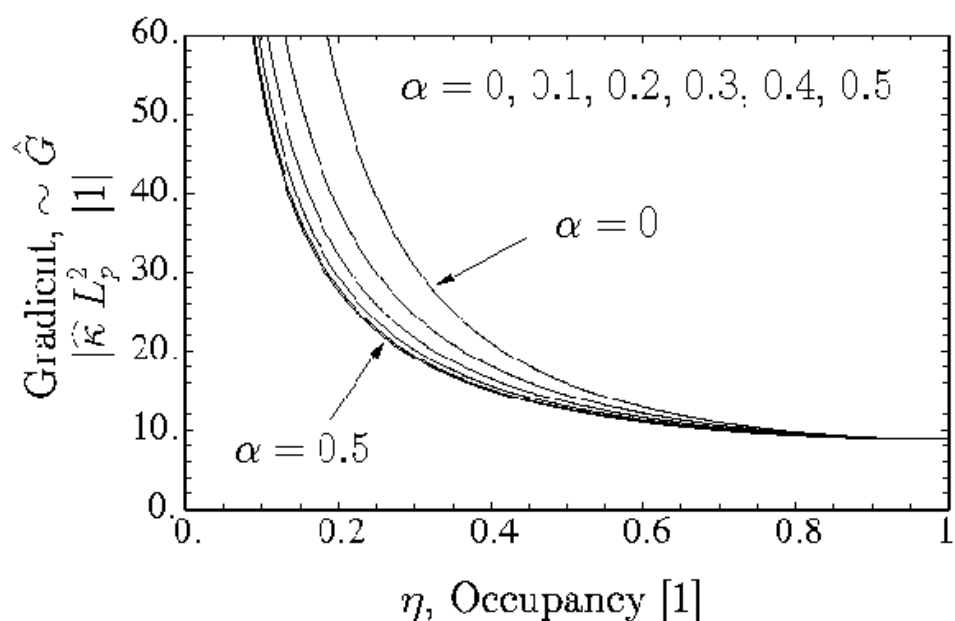

- ◆ Exact solutions plotted dashed almost overlay with approx thin lens (next sec)
- ◆ **Gradient** and **integrated gradient** required depend only weakly on synchrotron factor  $\alpha$  when  $\alpha$  is near or larger than  $1/2$
- ◆ Stronger **gradient** required for low occupancy  $\eta$  but integrated gradient varies comparatively less with  $\eta$  except for small  $\alpha$

///

## Contrast of Principal Orbits for different focusing:

- ◆ Use previous examples with “equivalent” focusing strength  $\sigma_0 = 60^\circ$
- ◆ Note that periodic focusing adds harmonic structure: increasing for AG focus

### 1) Continuous Focusing

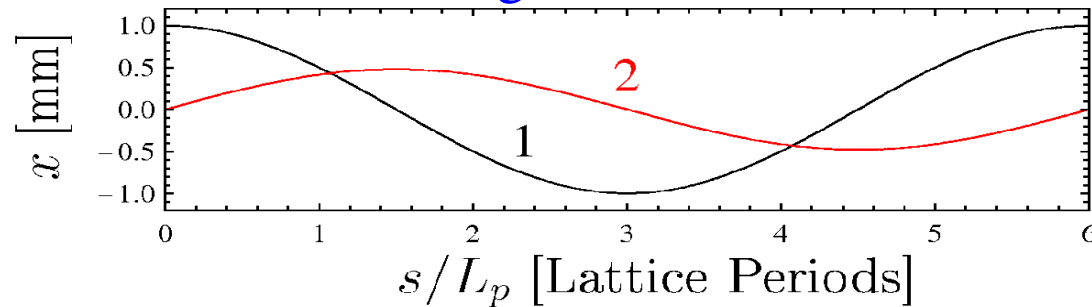

Simple Harmonic Oscillator

### 2) Periodic Solenoidal Focusing (Larmor Frame)

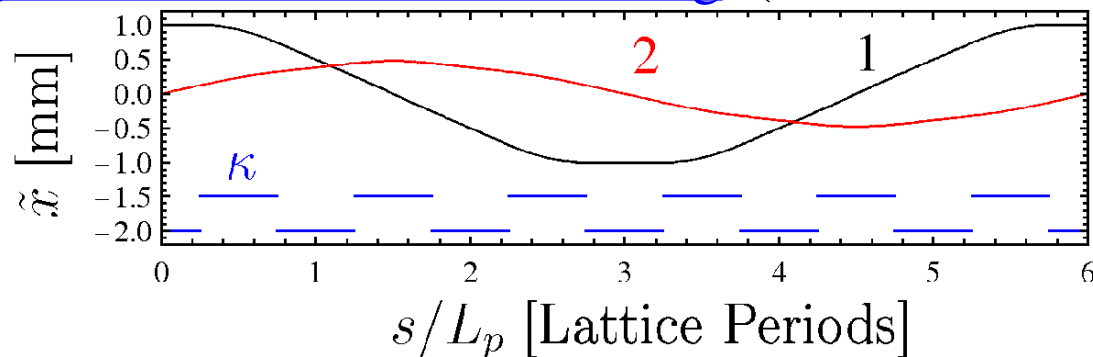

Simple harmonic oscillations modified with additional harmonics due to periodic focus

### 3) Periodic FODO Quadrupole Doublet Focusing

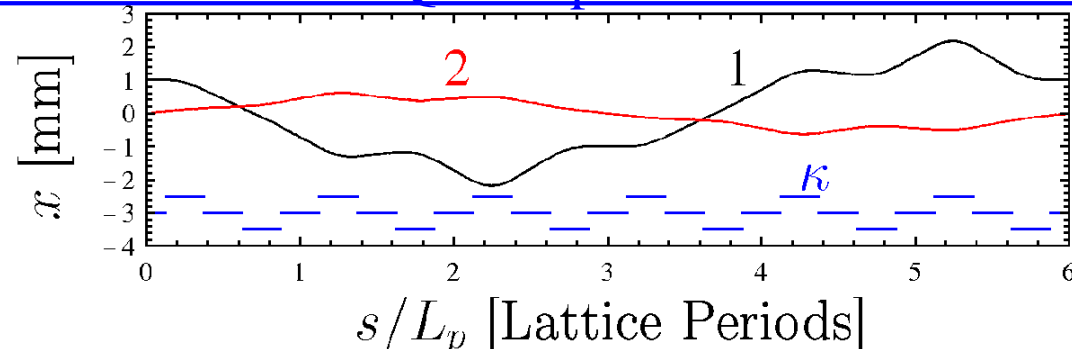

Simple harmonic oscillations more strongly modified due to periodic AG focus

## 4) Thin Lens Limits

Convenient to simply understand analytic scaling

$$\kappa_x(s) = \frac{1}{f} \delta(s - s_0)$$

$s_0 = \text{Optic Location} = \text{const}$

$f = \text{focal length} = \text{const}$

Transfer Matrix:

$$\begin{bmatrix} x \\ x' \end{bmatrix}_{s=s_0^+} = \begin{bmatrix} 1 & 0 \\ -1/f & 1 \end{bmatrix} \cdot \begin{bmatrix} x \\ x' \end{bmatrix}_{s=s_0^-}$$

Graphical Interpretation:

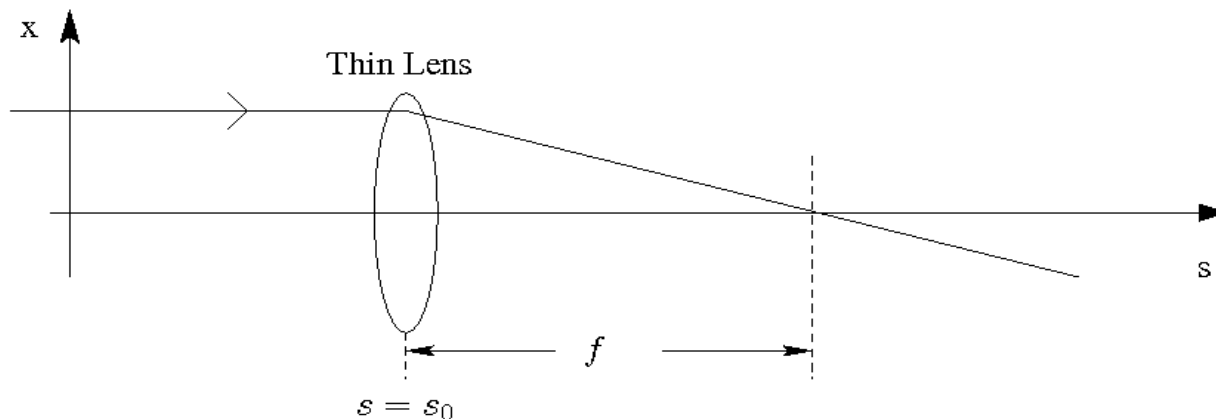

The thin lens limit of “thick” hard-edge solenoid and quadrupole focusing lattices presented can be obtained by taking:

**Solenoids:**  $\hat{\kappa} \equiv \frac{1}{\eta f L_p}$  then take  $\lim_{\eta \rightarrow 0}$

**Quadrupoles:**  $\hat{\kappa} \equiv \frac{2}{\eta f L_p}$  then take  $\lim_{\eta \rightarrow 0}$

This obtains when applied in the previous formulas:

$$\cos \sigma_0 = \begin{cases} 1 - \frac{1}{2} \frac{L_p}{f}, & \text{thin-lens periodic solenoid} \\ 1 - \frac{\alpha}{2} (1 - \alpha) \left( \frac{L_p}{f} \right)^2, & \text{thin-lens quadrupole doublet} \\ \alpha = \frac{1}{2} \implies \text{FODO} \end{cases}$$

These formulas can also be derived directly from the drift and thin lens transfer matrices as

### Periodic Solenoid

$$\cos \sigma_0 = \frac{1}{2} \text{Tr} \begin{bmatrix} 1 & L_p \\ 0 & 1 \end{bmatrix} \begin{bmatrix} 1 & 0 \\ -\frac{1}{f} & 1 \end{bmatrix} = 1 - \frac{1}{2} \frac{L_p}{f}$$

### Periodic FODO Quadrupole Doublet

$$\cos \sigma_0 = \frac{1}{2} \text{Tr} \begin{bmatrix} 1 & 0 \\ -\frac{1}{f} & 1 \end{bmatrix} \begin{bmatrix} 1 & \alpha L_p \\ 0 & 1 \end{bmatrix} \begin{bmatrix} 1 & 0 \\ \frac{1}{f} & 1 \end{bmatrix} \begin{bmatrix} 1 & (1 - \alpha) L_p \\ 0 & 1 \end{bmatrix} = 1 - \frac{\alpha}{2} (1 - \alpha) \left( \frac{L_p}{f} \right)^2$$



Expanded phase advance formulas (thin lens type limit and similar) can be useful in system design studies

- ◆ Desirable to derive simple formulas relating magnet parameters to  $\sigma_0$ 
  - Clear analytic scaling trends clarify design trade-offs
- ◆ For hard edge periodic lattices, expand formula for  $\cos \sigma_0$  to leading order in  $\Theta = \sqrt{|\hat{\kappa}|} \eta L_p / 2$

### /// Example: Periodic Quadrupole Doublet Focusing:

Expand previous phase advance formula for syncopated quadrupole doublet to obtain:

$$\cos \sigma_0 = 1 - \frac{(\eta \hat{\kappa} L_p^2)^2}{32} \left[ \left(1 - \frac{2}{3} \eta\right) - 4 \left(\alpha - \frac{1}{2}\right)^2 (1 - \eta)^2 \right]$$

where:

$$\hat{\kappa} = \begin{cases} \frac{\hat{G}}{[B\rho]}, & \text{Magnetic Quadrupoles} \\ \frac{\hat{G}}{\beta_{bc}[B\rho]}, & \text{Electric Quadrupoles} \end{cases} \quad \hat{G} = \text{Hard-Edge Field Gradient}$$

## Appendix A: Calculation of $w(s)$ from Principal Orbit Functions

Evaluate principal orbit expressions of the transfer matrix through one lattice period using

$$w(s_i + L_p) = w_i$$

$$w'(s_i + L_p) = w'_i$$

and

$$\Delta\psi(s_i + L_p) = \int_{s_i}^{s_i + L_p} \frac{ds}{w^2(s)} = \sigma_0$$

to obtain (see **S6F** for principal orbit formulas in phase-amplitude form):

$$\text{Example: } C(s|s_i) = \frac{w(s)}{w_i} \cos \Delta\psi(s) - w_i w(s) \sin \Delta\psi(s)$$

$$\implies C(s_i + L_p|s_i) = \cos \sigma_0 - w_i w'_i \sin \sigma_0$$

$$S(s_i + L_p|s_i) = w_i^2 \sin \sigma_0$$

$$C'(s_i + L_p|s_i) = - \left( \frac{1}{w_i^2} + w_i w'_i \right) \sin \sigma_0$$

$$S'(s_i + L_p|s_i) = \cos \sigma_0 + w_i w'_i \sin \sigma_0$$

Giving:

$$w_i = \sqrt{\frac{S(s_i + L_p | s_i)}{\sin \sigma_0}}$$
$$w'_i = \frac{\cos \sigma_0 - C(s_i + L_p | s_i)}{\sqrt{S(s_i + L_p | s_i) \sin \sigma_0}}$$

Apply  $C(s|s_i)$  Eqn.

Apply  $S(s|s_i)$  Eqn.  
+  $w_i$  Result Above

Or in terms of the betatron formulation (see: **S7** and **S8**) with

$$\beta = w^2, \quad \beta' = 2ww'$$

$$\beta_i = w_i^2 = \frac{S(s_i + L_p | s_i)}{\sin \sigma_0}$$
$$\beta'_i = 2w_i w'_i = \frac{2[\cos \sigma_0 - C(s_i + L_p | s_i)]}{\sin \sigma_0}$$

Next, calculate  $w$  from the principal orbit expression (**S6F**) in phase-amplitude

form

$$\frac{S}{w_i w} = \sin \Delta\psi$$

$$S \equiv S(s|s_i) \text{ etc.}$$

$$\frac{w_i}{w} C + \frac{w'_i}{w} S = \cos \Delta\psi$$

**A2**

Square and add equations:

$$\left(\frac{S}{w_i w}\right)^2 + \left(\frac{w_i C}{w} + \frac{w'_i S}{w}\right)^2 = 1$$

- ◆ This result reflects the structure of the underlying Courant-Snyder invariant (see: **S7**)

Gives:

$$w^2 = \left(\frac{S}{w_i}\right)^2 + (w_i C + w'_i S)^2$$

Use  $w_i, w'_i$  previously identified and write out result:

$$w^2(s) = \beta(s) = \sin^2 \sigma_0 \frac{S^2(s|s_i)}{S(s_i + L_p|s_i)} + \frac{S(s_i + L_p|s_i)}{\sin \sigma_0} \left[ C(s|s_i) + \frac{\cos \sigma_0 - C(s_i + L_p|s_i)}{S(s_i + L_p|s_i)} S(s|s_i) \right]^2$$

- ◆ Formula shows that for a given  $\sigma_0$  (used to specify lattice focusing strength),  $w(s)$  is given by two linear principal orbits calculated over one lattice period
  - Easy to apply numerically

An alternative way to calculate  $w(s)$  is as follows. 1<sup>st</sup> apply the phase-amplitude formulas for the principal orbit functions with:

$$s_i \rightarrow s$$

$$s \rightarrow s + L_p$$

$$\Rightarrow \begin{aligned} C(s + L_p|s) &= \cos \sigma_0 - w(s)w'(s) \sin \sigma_0 \\ S(s + L_p|s) &= w^2(s) \sin \sigma_0 \end{aligned}$$

$$w^2(s) = \beta(s) = \frac{S(s + L_p|s)}{\sin \sigma_0} = \frac{\mathbf{M}_{12}(s + L_p|s)}{\sin \sigma_0}$$

- Formula requires calculation of  $S(s + L_p|s)$  at every value of  $s$  within lattice period
- Previous formula requires one calculation of  $C(s|s_i)$ ,  $S(s|s_i)$  for  $s_i \leq s \leq s_i + L_p$  and any value of  $s_i$

Matrix algebra can be applied to simplify this result:



$$\begin{aligned}
 \mathbf{M}(s + L_p | s) &= \mathbf{M}(s + L_p | s_i + L_p) \cdot \mathbf{M}(s_i + L_p | s) \\
 &= \mathbf{M}(s | s_i) \cdot \mathbf{M}(s_i + L_p | s) \cdot [\mathbf{M}(s | s_i) \cdot \mathbf{M}^{-1}(s | s_i)] \\
 &= \mathbf{M}(s | s_i) \cdot \mathbf{M}(s_i + L_p | s_i) \cdot \mathbf{M}^{-1}(s | s_i)
 \end{aligned}$$

$$\mathbf{M}(s + L_p | s) = \mathbf{M}(s | s_i) \cdot \mathbf{M}(s_i + L_p | s_i) \cdot \mathbf{M}^{-1}(s | s_i)$$

- Using this result with the previous formula allows the transfer matrix to be calculated only once per period from any initial condition

Using:

$$\mathbf{M} = \begin{pmatrix} C & S \\ C' & S' \end{pmatrix} \quad \mathbf{M}^{-1} = \begin{pmatrix} S' & -S \\ -C' & C \end{pmatrix}$$

Apply Wronskian condition:

$$\det \mathbf{M} = 1$$

The matrix formula can be shown to be equivalent to the previous one

- Methodology applied in: Lund, Chilton, and Lee, PRSTAB **9** 064201 (2006) to construct a fail-safe iterative matched envelope including space-charge **A5**

# Corrections and suggestions for improvements welcome!

These notes will be corrected and expanded for reference and for use in future editions of US Particle Accelerator School (USPAS) and Michigan State University (MSU) courses. Contact:

Prof. Steven M. Lund  
Facility for Rare Isotope Beams  
Michigan State University  
640 South Shaw Lane  
East Lansing, MI 48824

[lund@frib.msu.edu](mailto:lund@frib.msu.edu)

(517) 908 – 7291 office

(510) 459 - 4045 mobile

Please provide corrections with respect to the present archived version at:

[https://people.nscl.msu.edu/~lund/msu/phy905\\_2020/](https://people.nscl.msu.edu/~lund/msu/phy905_2020/)

Redistributions of class material welcome. Please do not remove author credits.